

Tuesday 10 November 2020 – Morning

GCSE (9–1) Chemistry B (Twenty First Century Science)

J258/03 Breadth in Chemistry (Higher Tier)

Time allowed: 1 hour 45 minutes

**You must have:**

- a ruler (cm/mm)
- the Data Sheet for GCSE (9–1) Chemistry B (inside this document)

**You can use:**

- an HB pencil
- a scientific or graphical calculator



Please write clearly in black ink. **Do not write in the barcodes.**

Centre number

--	--	--	--	--

Candidate number

--	--	--	--

First name(s)

---

Last name

---

**INSTRUCTIONS**

- Use black ink. You can use an HB pencil, but only for graphs and diagrams.
- Write your answer to each question in the space provided. If you need extra space use the lined pages at the end of this booklet. The question numbers must be clearly shown.
- Answer **all** the questions.
- Where appropriate, your answer should be supported with working. Marks might be given for using a correct method, even if your answer is wrong.

**INFORMATION**

- The total mark for this paper is **90**.
- The marks for each question are shown in brackets [ ].
- This document has **24** pages.

**ADVICE**

- Read each question carefully before you start your answer.

Answer **all** the questions.

- 1 Layla does a titration to find out the concentration of some sodium hydroxide solution. She reacts hydrochloric acid with the sodium hydroxide solution.

- (a) Layla says, 'The titration uses a **neutralisation** reaction.'

Define a neutralisation reaction.

.....  
 ..... [1]

- (b) This is Layla's **incomplete** method for the titration:

- Put the hydrochloric acid in a burette.
- Put the sodium hydroxide solution in a flask.
- Add the hydrochloric acid to the sodium hydroxide solution.
- Stop adding the hydrochloric acid when the sodium hydroxide solution is neutralised.

- (i) Layla needs to add another substance to the flask so that she knows when to stop adding the hydrochloric acid.

Which substance does Layla need to add, **and** what will she see?

Layla needs to add .....

Layla will see ..... [2]

- (ii) Layla titrates the hydrochloric acid into a flask from a burette. She wants to make sure her final burette reading is as **accurate** as possible.

Describe **one** thing Layla can do to make her reading as accurate as possible.

.....  
 ..... [1]

- (c) (i) Layla's results for her rough titration are shown in **Table 1.1**.

Complete **Table 1.1** by calculating the volume for the rough titration.

	<b>Rough titration</b>
<b>Initial burette reading (cm<sup>3</sup>)</b>	0.90
<b>Final burette reading (cm<sup>3</sup>)</b>	25.80
<b>Volume for the rough titration (cm<sup>3</sup>)</b>	.....

**Table 1.1**

[1]

- (ii) Layla's repeat readings for her careful titrations are shown in **Table 1.2**.

	<b>First titration</b>	<b>Second titration</b>	<b>Third titration</b>	<b>Fourth titration</b>
<b>Volume (cm<sup>3</sup>)</b>	24.55	24.95	24.65	24.60

**Table 1.2**

Layla calculates that the mean titration volume is 24.60 cm<sup>3</sup>.

Explain why Layla is correct.

Use the information in **Table 1.2** and a calculation in your answer.

.....

.....

.....

..... [2]

- (iii) Calculate the mass of acid in 1 cm<sup>3</sup> of hydrochloric acid.

Use the formula: mean titration volume =  $\frac{0.0908}{\text{mass of acid in 1 cm}^3 \text{ of hydrochloric acid}}$

Give your answer to **2** significant figures.

Mass of acid in 1 cm<sup>3</sup> of hydrochloric acid = ..... g [4]

2 Beth has some tablets that react by fizzing, and then dissolving, when water is added.

Beth puts a whole tablet into **Tube A**, and a broken-up tablet into **Tube B**.

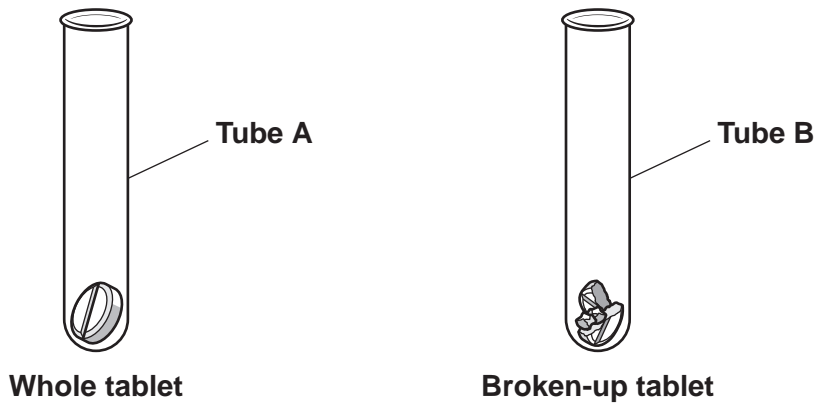

Fig. 2.1

(a) Beth wants to measure the rate of the two reactions. This is Beth's method:

- Add the same volume of **cold** water to each test tube at the same time.
- Start a stopwatch.

(i) When should Beth stop the stopwatch?

Tick (✓) **one** box.

When the bubbles start to appear.

When the fizzing starts.

When the fizzing stops.

When only a small amount of tablet is left.

[1]

(ii) Which type of tablet, whole or broken-up, will dissolve more quickly?

Whole tablet

Broken-up tablet

Explain your answer.

Use ideas from the particle model in your answer.

.....

.....

..... [2]

- (b) Suggest **one** reason why the reactions are much faster using **hot** water.

.....  
 ..... [1]

- (c) **Fig. 2.2** shows how the mass of **Tube A** and its contents changes over time when cold water is added.

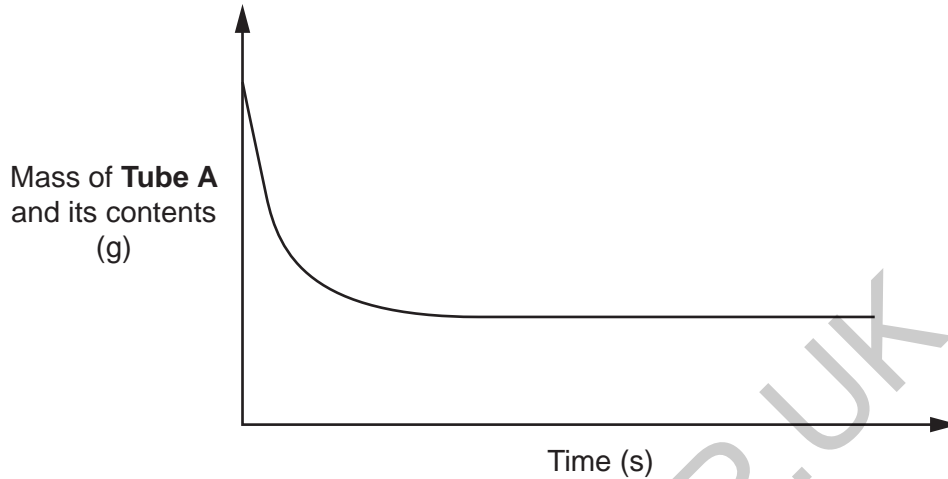

**Fig. 2.2**

- (i) Using **Fig. 2.2**, explain why the mass of **Tube A** and its contents decreases during the reaction.

.....  
 ..... [1]

- (ii) The rate of the reaction decreases with time.

Describe how **Fig. 2.2** shows this.

.....  
 ..... [1]

- (iii) Explain why the rate of reaction decreases with time.

.....  
 ..... [1]

3 Fig. 3.1 shows the displayed formula of ethene.

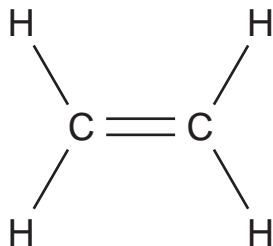

Fig. 3.1

(a) Ethene has some reactions that are different from those of ethane. These reactions are caused by its functional group.

Put a (ring) around the functional group of ethene in Fig. 3.1.

[1]

(b) 1 mole of ethene contains  $6.0 \times 10^{23}$  molecules.

How many hydrogen atoms are there in one mole of ethene?

Put a (ring) around the correct answer.

1            4            6             $6.0 \times 10^{23}$              $2.4 \times 10^{24}$

[1]

(c) (i) Ethene (Fig. 3.1) reacts with **Substance D** to give the compound shown in Fig. 3.2.

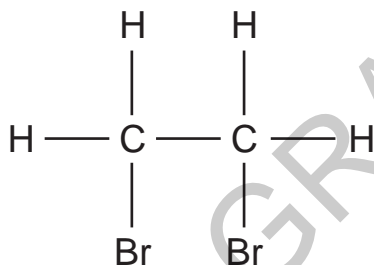

Fig. 3.2

Name **Substance D**.

..... [1]

(ii) Ethene also reacts with hydrogen.

Draw the displayed formula of the compound formed.

4 Fig. 4.1 shows how the average world temperature has changed since 1880.

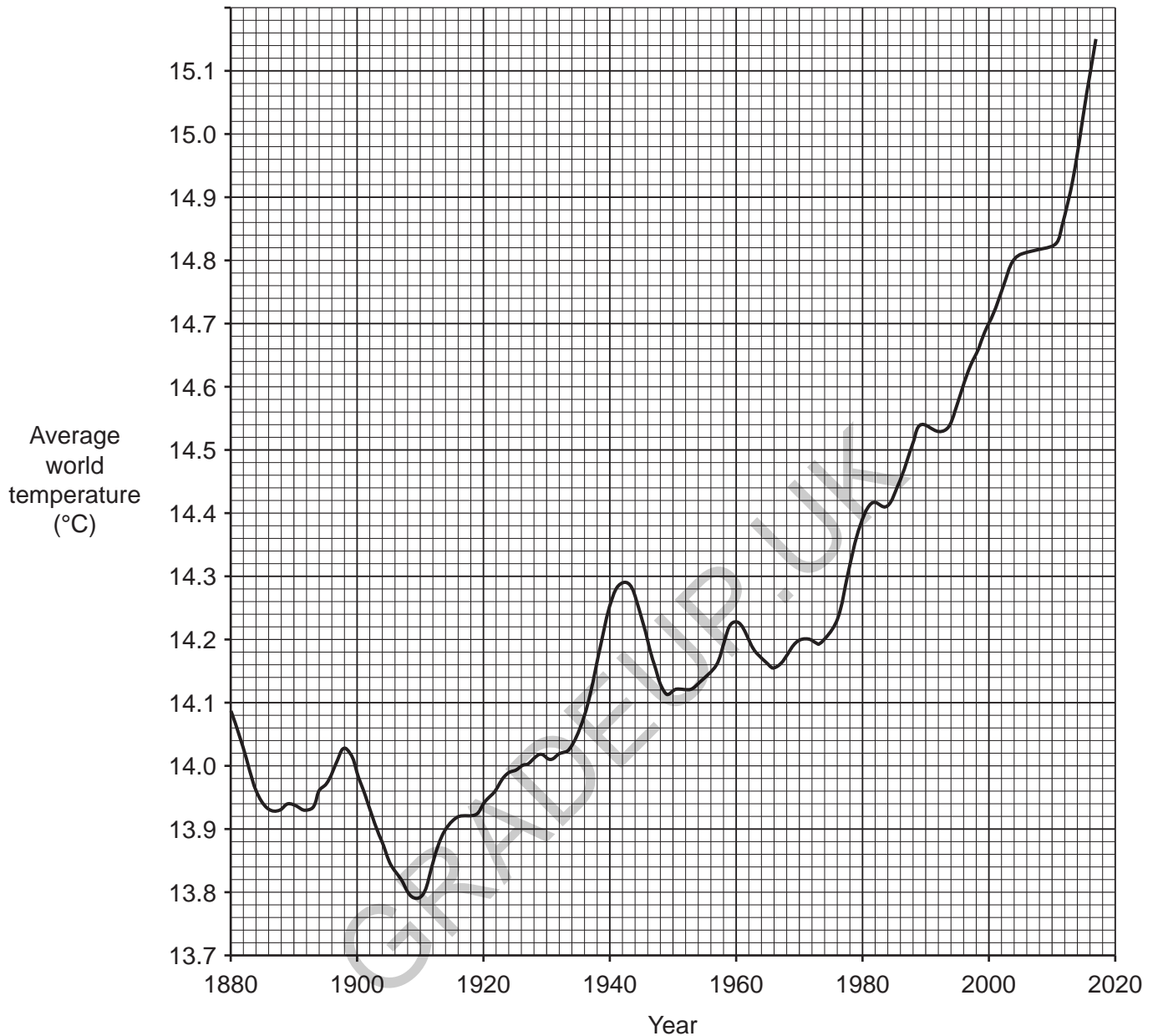

Fig. 4.1

- (a) (i) Using Fig. 4.1, describe how the average world temperature changed from 1910–1930.  
 ..... [1]
- (ii) Between which **two** years was there the largest **continuous** temperature rise?  
 Between ..... and ..... [1]

- (b) (i) Some scientists believe that average world temperatures have increased due to increased amounts of greenhouse gases in the air.

Carbon dioxide is a greenhouse gas.

Amaya says,

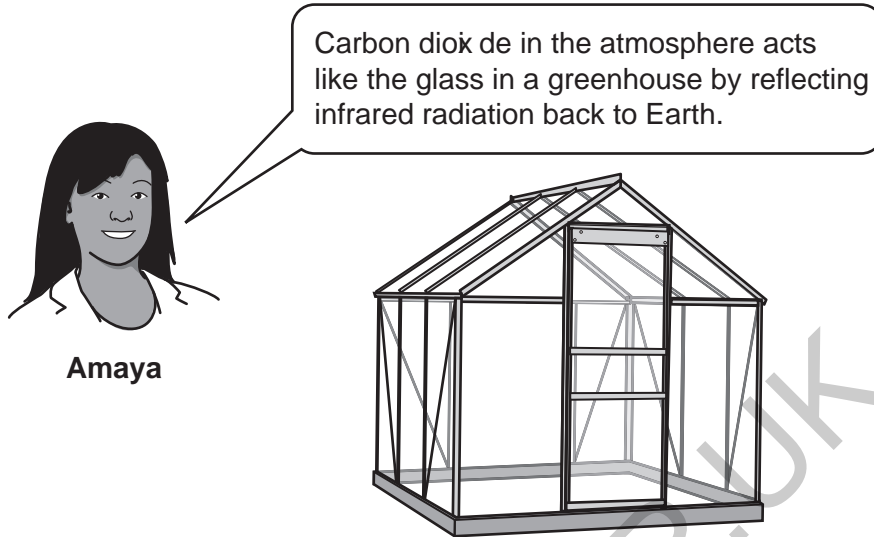

Explain what is **incorrect** about Amaya's statement.

.....

.....

.....

..... [2]

- (ii) State **one** suitable way in which we can lower our carbon dioxide emissions.

.....

..... [1]

- (c) State **one** effect of increasing average world temperatures on the Earth's climate.

..... [1]

5 Amir is given a solution of potassium sulfate, which can be used as a fertiliser.

(a) He carries out a flame test on the solution.

(i) Describe how Amir does the flame test.

.....  
 .....  
 .....  
 .....  
 ..... [3]

(ii) What colour does Amir see when he carries out the flame test on potassium sulfate?

..... [1]

(b) Write a **balanced symbol** equation for the reaction of potassium sulfate ( $K_2SO_4$ ) solution with barium chloride ( $BaCl_2$ ) solution.

Show state symbols.

..... [3]

(c) Amir has a sample of another fertiliser, **Fertiliser E**.

He looks at the emission spectra of **Fertiliser E** and potassium sulfate:

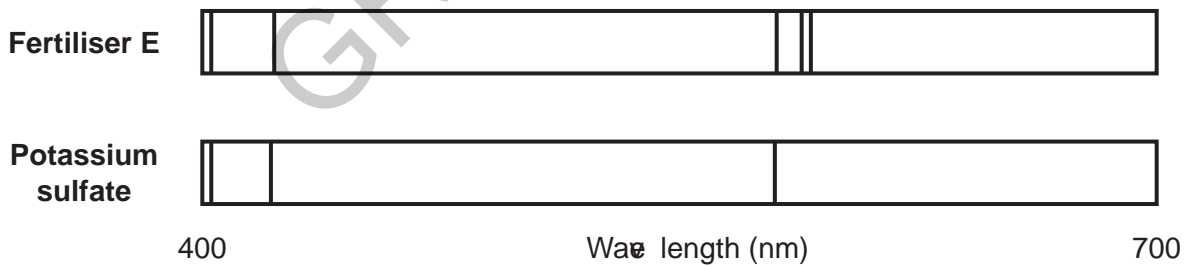

(i) What can Amir conclude about **Fertiliser E** from these emission spectra?

.....  
 ..... [1]

(ii) Compounds can be analysed using a flame test **or** an emission spectrum.

State **one** advantage of using an emission spectrum to analyse compounds.

.....  
 ..... [1]

6 Iron is an important metal in the construction industry. The main disadvantage of iron is that it rusts.

Jane and Ben investigate the rusting of iron nails using two test tubes, X and Y.

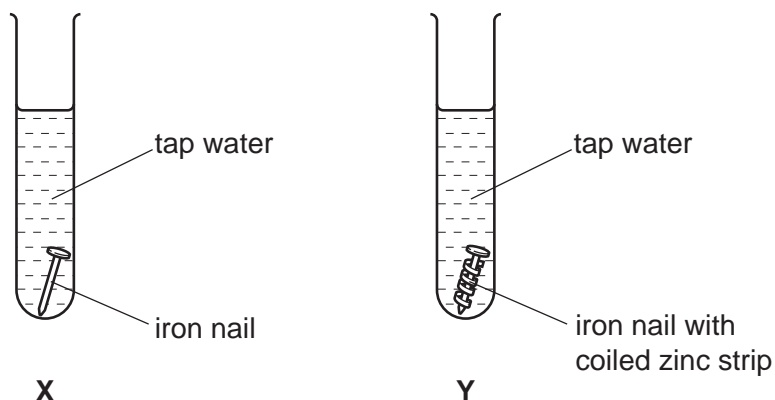

(a) Jane and Ben discuss the investigation:

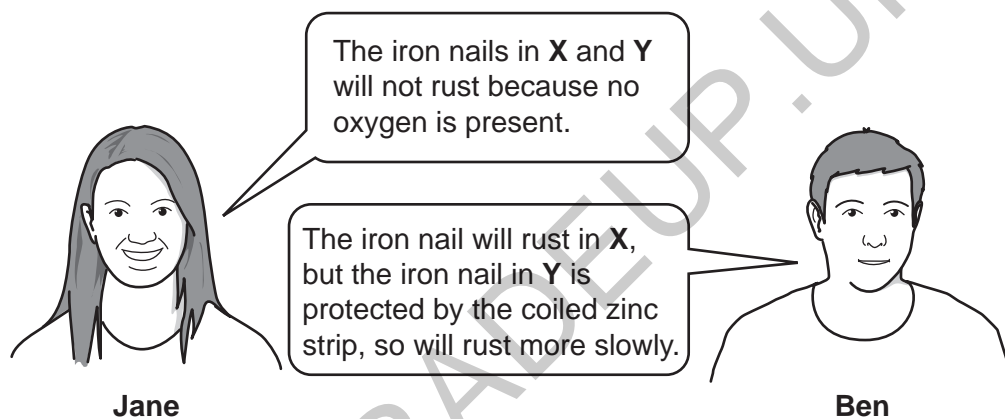

Do you agree with each person's comments?

Give **one** reason for each of your answers.

Jane .....

.....

Ben .....

.....

[2]

(b) When iron rusts, an iron(III) cation is made.

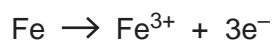

(i) What is being oxidised in this reaction?

Put a (ring) around the correct formula.

**Fe**

**Fe<sup>3+</sup>**

**3e<sup>-</sup>**

[1]

(ii) Give **one** reason for your answer to (b)(i).

.....

..... [1]

(c) Jane collects the rust. She dissolves the rust in hydrochloric acid and adds some sodium hydroxide solution.

She sees a brown precipitate.

What is the name of this brown precipitate?

Tick (✓) **one** box.

Iron(III) chloride

Iron(II) hydroxide

Iron(III) hydroxide

Sodium chloride

[1]

7 Drinking cups can be made from poly(propene) or aluminium.

(a) Poly(propene) is made from propene.

The displayed formula for propene is shown below:

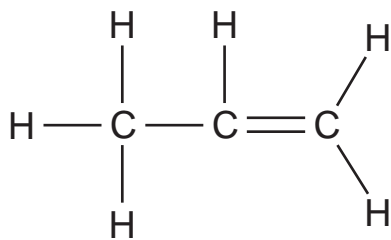

(i) What is the empirical formula of propene?

..... [1]

(ii) Draw the structure for a repeating unit of poly(propene).

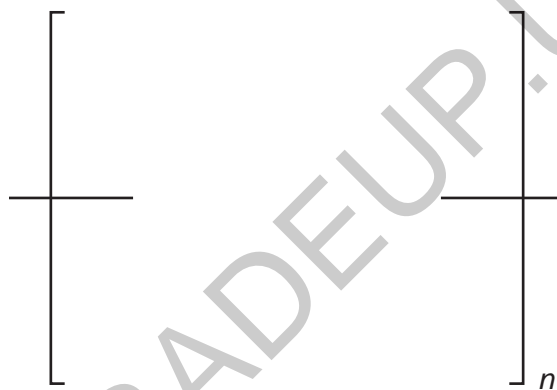

[2]

- (b) Aluminium melts at 660 °C. Poly(propene) melts at 130 °C.

Hot water from a kettle has a temperature of between 90 °C and 100 °C.

James says,



**James**

Aluminium drinking cups are better than poly(propene) cups. They are less likely to go soft when hot water is added from a kettle.

Do you agree with James?

**Yes**

**No**

Explain your answer.

.....

..... [1]

- (c) Which statements about polymers are **true**, and which are **false**?

Tick (✓) **one** box in each row.

	<b>True</b>	<b>False</b>
When monomers form condensation polymers, a small molecule is also formed.		
DNA is a polymer formed from nucleotides.		
To make a condensation polymer, each monomer needs only one functional group.		

[3]

8 Diamond and graphite are allotropes of carbon.

Models of diamond and graphite are shown in **Fig. 8.1**:

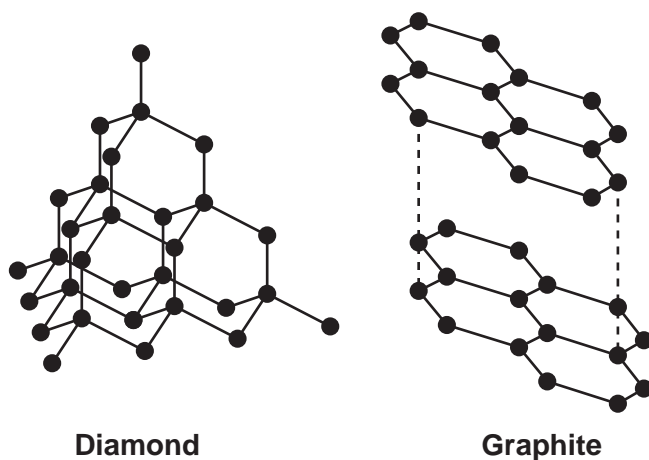

**Fig. 8.1**

(a) Graphite can mark paper but diamond **cannot**.

Explain why.

Use ideas about intermolecular forces and bonding in your answer.

.....

.....

.....

.....

.....

.....

.....

**[3]**

(b) Fig. 8.2 shows a model of sodium chloride:

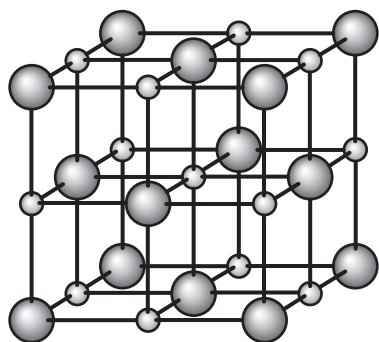

Fig. 8.2

What type of structure does sodium chloride have?

You should include the type of bonding in your answer.

..... [1]

(c) Complete the table to explain how graphite and sodium chloride conduct electricity.

	Graphite	Sodium chloride
Conducts electricity when:	solid	either molten or .....
Particles responsible for conduction of electricity:	.....	.....

[3]

9 Ammonia is used to make synthetic fertilisers.

Ammonia is made by the Haber process.

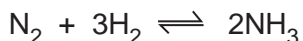

(a) The reaction in the Haber process reaches equilibrium.

Describe the rates of the forward and reverse reactions at equilibrium.

.....  
 ..... [1]

(b) The graph shows the effect of temperature and pressure on the yield of ammonia in the Haber process:

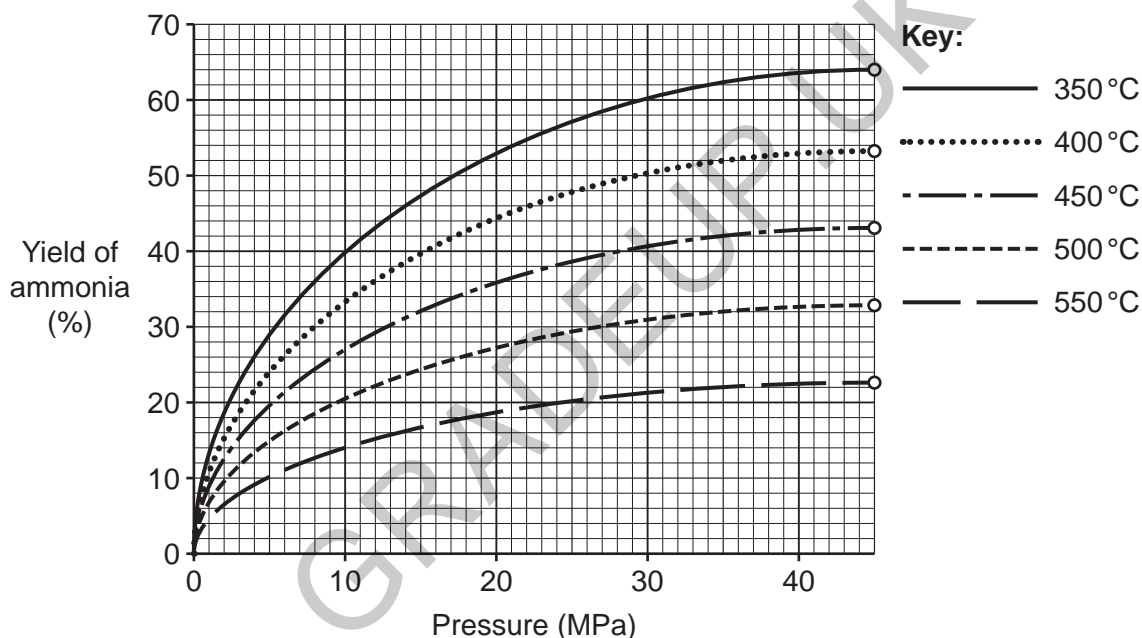

(i) State the **lowest** temperature and pressure necessary to get a yield of ammonia of 15%.

Temperature = ..... °C

Pressure = ..... MPa

[1]

(ii) Suggest **one** disadvantage of using a temperature of 350 °C rather than 450 °C in the Haber process.

.....  
 ..... [1]

(iii) A reactor starts with 12.0 tonnes of hydrogen and excess nitrogen.

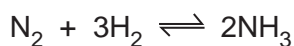

How many **tonnes of ammonia** would be produced from  $6 \times 10^6$  moles of hydrogen,  $\text{H}_2$ ?

1 tonne =  $1 \times 10^6$  g

Use the equation: number of moles =  $\frac{\text{mass of substance (g)}}{\text{relative formula mass (g)}}$

Mass of ammonia = ..... tonnes [3]

(c) Sarah makes ammonium sulfate from ammonia in a laboratory. This is her method:

- Add excess ammonia to dilute sulfuric acid in an evaporating basin.
- Boil the solution until it does not smell of ammonia.
- Cool the basin until crystals form in the solution.

The crystals that form in the solution are **impure**.

Describe what Sarah can do to get pure ammonium sulfate crystals.

.....  
 .....  
 .....  
 ..... [2]

(d) Ammonium sulfate can be mixed with other substances to make compound fertilisers.

Suggest why compound fertilisers are better for farmers than pure ammonium sulfate.

.....  
 ..... [1]

10 Lithium-ion batteries are used in phones, tablets and electric cars.

(a) Lithium reacts with chlorine to form lithium chloride.

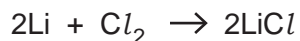

What mass of chlorine reacts with 1 g of lithium?

Use the equation: number of moles =  $\frac{\text{mass of substance (g)}}{\text{relative formula mass (g)}}$

Give your answer to 1 decimal place.

Mass of chlorine = ..... g [3]

(b) Lithium reacts with water to form lithium hydroxide (LiOH) and a gas.

Write a balanced symbol equation for this reaction.

..... [2]

(c) Lithium is made by the electrolysis of molten lithium chloride.

Name the product formed at each electrode.

Cathode .....

Anode .....

[2]

(d) Nina does some experiments with chlorine.

- (i) Nina wants to use a displacement reaction to show chlorine is more reactive than bromine.

Describe what Nina needs to do and what she will see.

Nina needs to .....

Nina will see .....

[2]

- (ii) Nina has to be careful when using chlorine in her experiments.

State **one** precaution she must take **and** why the precaution is needed.

Precaution

.....

Why the precaution is needed

.....

[2]

20  
BLANK PAGE

PLEASE DO NOT WRITE ON THIS PAGE

GRADEUP.UK

11 Titanium is used for hip replacements.

(a) Titanium's strength comes from its metallic structure as shown in **Fig. 11.1**.

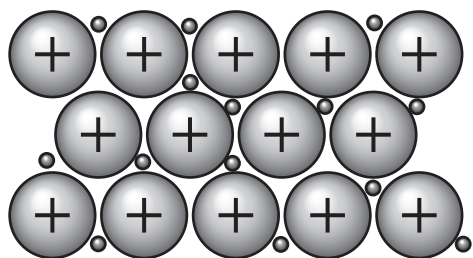

**Fig. 11.1**

Use **Fig. 11.1** to explain why the metallic bonds in titanium are very strong.

.....

.....

..... [2]

(b) Titanium is a transition metal. Calcium is **not** a transition metal.

Which **two** statements are correct about both calcium and titanium?

Tick (✓) **two** boxes.

They both conduct electricity.

They both form cations.

They both form coloured ions in solution.

They both form ions with several different charges.

They both react with cold water.

[2]

- (c) Titanium can be made from titanium oxide by two methods.

**Method 1** uses magnesium reacting with titanium oxide:  
 $2\text{Mg} + \text{TiO}_2 \rightarrow \text{Ti} + 2\text{MgO}$

**Method 2** uses the electrolysis of titanium oxide:  
 $\text{TiO}_2 \rightarrow \text{Ti} + \text{O}_2$

The atom economies of the two methods can be compared using this equation:

$$\text{atom economy} = \frac{\text{mass of atoms in desired product}}{\text{total mass of atoms in reactants}} \times 100\%$$

- (i) What does atom economy tell us about a reaction?

.....  
 ..... [1]

- (ii) Calculate the atom economy of **Method 2**.

Give your answer to **2** significant figures.

Atom economy = ..... % [3]

- (iii) Explain, **without further calculation**, which method has the higher atom economy.

.....  
 .....  
 ..... [1]

(iv) Jamal and Mia discuss atom economy.

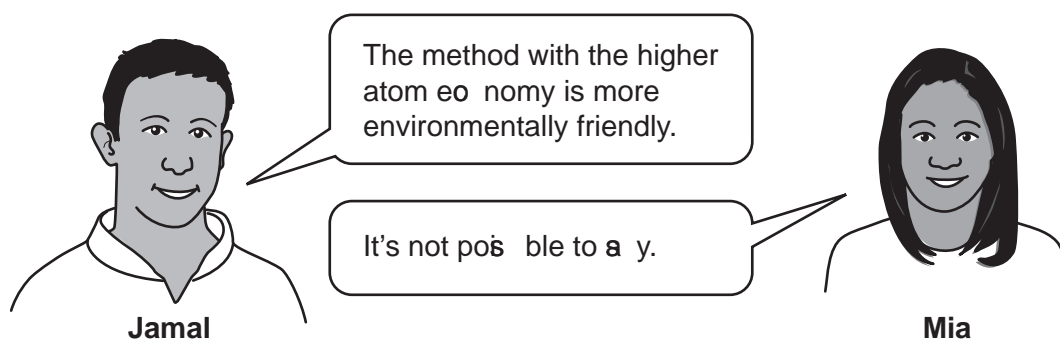

Evaluate Jamal and Mia's comments.

.....

.....

.....

.....

.....

[3]

(d) Magnesium oxide (MgO) is formed in **Method 1**.

Complete **Fig. 11.2** to show the 'dot and cross' diagrams for an  $\text{Mg}^{2+}$  ion and an  $\text{O}^{2-}$  ion.

Show all the electrons.

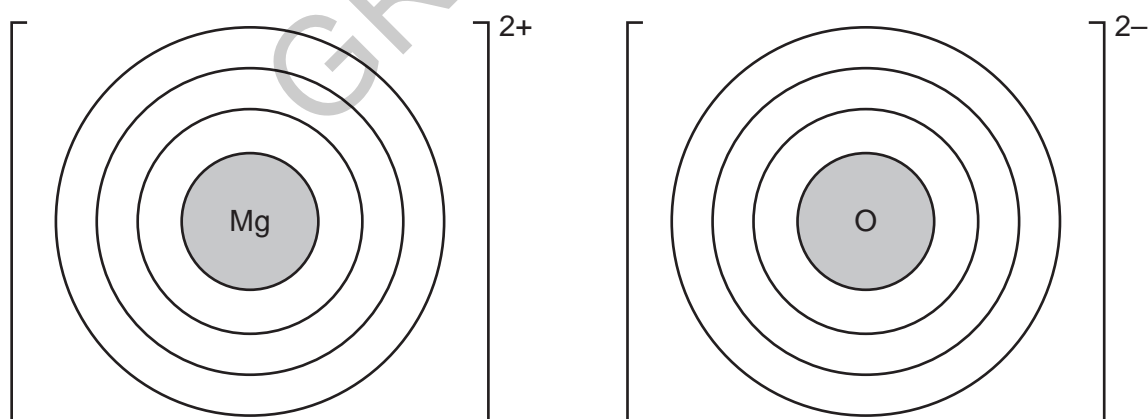

Fig. 11.2

[2]

END OF QUESTION PAPER

