

**Tuesday 10 November 2020 – Morning**

**GCSE (9–1) Chemistry A (Gateway Science)**

**J248/01 Paper 1 (Foundation Tier)**

**Time allowed: 1 hour 45 minutes**

**You must have:**

- a ruler (cm/mm)
- the Data Sheet for GCSE (9–1) Chemistry A (inside this document)

**You can use:**

- a scientific or graphical calculator
- an HB pencil



Please write clearly in black ink. **Do not write in the barcodes.**

Centre number

--	--	--	--	--

Candidate number

--	--	--	--

First name(s)

---

Last name

---

### INSTRUCTIONS

- Use black ink. You can use an HB pencil, but only for graphs and diagrams.
- Write your answer to each question in the space provided. If you need extra space use the lined pages at the end of this booklet. The question numbers must be clearly shown.
- Answer **all** the questions.
- Where appropriate, your answer should be supported with working. Marks might be given for using a correct method, even if the answer is wrong.

### INFORMATION

- The total mark for this paper is **90**.
- The marks for each question are shown in brackets [ ].
- Quality of extended response will be assessed in questions marked with an asterisk (\*).
- This document has **32** pages.

### ADVICE

- Read each question carefully before you start your answer.

2

## SECTION A

Answer **all** the questions.

You should spend a maximum of 30 minutes on this section.

Write your answer to each question in the box provided.

- 1 Which separation technique is this equipment used for?

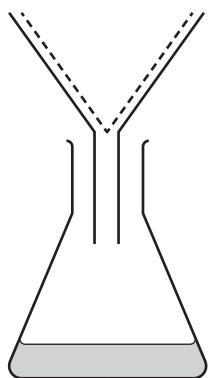

- A Crystallisation
- B Distillation
- C Evaporation
- D Filtration

Your answer

[1]

- 2 What is the position of **carbon** in the Periodic Table?

- A Period 1, Group 4
- B Period 2, Group 4
- C Period 4, Group 1
- D Period 4, Group 2

Your answer

[1]

- 3 Look at the balanced symbol equation.



What does the symbol **(s)** represent in the balanced symbol equation?

- A Solid
- B Solute
- C Solution
- D Substance

Your answer

[1]

- 4 The formula of magnesium chloride is  $\text{MgCl}_2$ .

What is the relative formula mass of magnesium chloride?

( $A_r$ : Mg = 24.3, Cl = 35.5)

- A 59.8
- B 95.3
- C 119.6
- D 84.1

Your answer

[1]

- 5 Sodium hydroxide reacts with hydrochloric acid. Sodium chloride and water are made.

What is the name of this type of reaction?

- A Neutralisation
- B Oxidation
- C Reduction
- D Thermal decomposition

Your answer

[1]

6 Neutralisation occurs when acids react with alkalis.

What is the ionic equation for neutralisation?

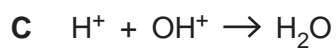
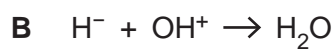
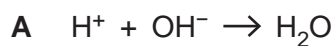

Your answer

[1]

7 Butane has the molecular formula  $\text{C}_4\text{H}_{10}$ .

What is the **empirical** formula of butane?



Your answer

[1]

8 Ammonia has a simple molecular structure.

Which statement explains why ammonia has a low melting point and a low boiling point?

A The covalent bonds between the atoms are strong.

B The covalent bonds between the atoms are weak.

C The intermolecular forces between the molecules are strong.

D The intermolecular forces between the molecules are weak.

Your answer

[1]

- 9 Ethanol,  $C_2H_5OH$ , burns in oxygen. Carbon dioxide and water are made.

Which equation for this reaction is correctly balanced?

- A  $C_2H_5OH + O_2 \rightarrow CO_2 + H_2O$   
B  $C_2H_5OH + 3O_2 \rightarrow 2CO_2 + 3H_2O$   
C  $C_2H_5OH + 2O_2 \rightarrow 3CO_2 + 2H_2O$   
D  $2C_2H_5OH + 7O_2 \rightarrow 4CO_2 + 6H_2O$

Your answer

[1]

- 10 The diagram shows an atom of an element.

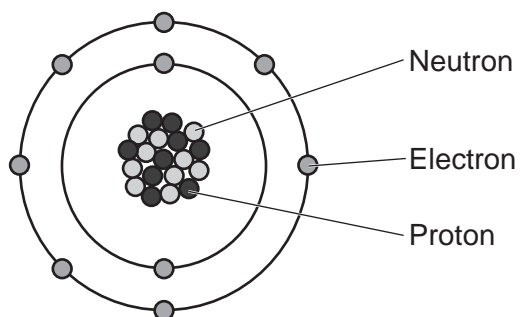

What is the name of the element?

- A Boron  
B Beryllium  
C Fluorine  
D Neon

Your answer

[1]

- 11 An aqueous solution of concentrated sodium chloride is electrolysed. Bubbles are seen at the **positive** electrode.

What is the name of the substance produced at the positive electrode?

- A Chlorine
- B Hydrogen
- C Sodium
- D Oxygen

Your answer

[1]

- 12 A potassium isotope can be shown as:



What are the numbers of protons, neutrons and electrons in this potassium isotope?

- A 19 protons, 19 neutrons, 20 electrons
- B 19 protons, 20 neutrons, 19 electrons
- C 20 protons, 19 neutrons, 19 electrons
- D 20 protons, 20 neutrons, 19 electrons

Your answer

[1]

- 13 Oxygen reacts with 1.20 g of carbon. 4.40 g of carbon dioxide forms.

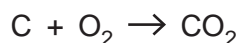

What mass of oxygen is used in this reaction?

- A 0.80 g
- B 1.60 g
- C 3.20 g
- D 5.60 g

Your answer

[1]

14 The symbol of an aluminium ion is  $Al^{3+}$ .

The symbol of an oxide ion is  $O^{2-}$ .

What is the formula of aluminium oxide?

- A  $AlO$
- B  $Al_2O$
- C  $Al_3O_2$
- D  $Al_2O_3$

Your answer

[1]

15 Substance Y melts at  $-7^\circ\text{C}$  and boils at  $59^\circ\text{C}$ .

What is the state of substance Y at room temperature?

- A Gas
- B Liquid
- C Plasma
- D Solid

Your answer

[1]

8  
BLANK PAGE

GRADEUP.UK

PLEASE DO NOT WRITE ON THIS PAGE

## SECTION B

Answer **all** the questions.

16 The particle model shows how particles are arranged and how they move in the three states of matter.

(a) (i) Draw a line to match each **diagram** with the correct **state of matter**.

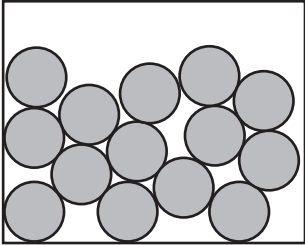
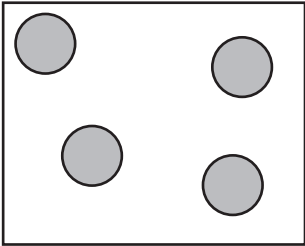
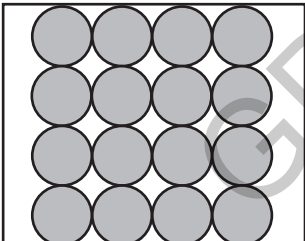
Diagram	State of matter
	<div style="border: 1px solid black; padding: 5px; display: inline-block;">Solid</div>
	<div style="border: 1px solid black; padding: 5px; display: inline-block;">Liquid</div>
	<div style="border: 1px solid black; padding: 5px; display: inline-block;">Gas</div>

[2]

(ii) When a liquid is heated to its boiling point, it will turn into a gas.

Use the particle model to explain why this is a **physical change**.

.....

..... [1]

(b) The table shows the properties of different substances.

Substance	Melting point (°C)	Boiling point (°C)	Soluble in water?	Conducts electricity in solid state?	Conducts electricity in molten state?
A	-210	-196	No	No	No
B	1084	2562	No	Yes	Yes
C	605	1137	Yes	No	Yes
D	-78	-34	Yes	No	No

(i) Which **two** substances are gases at room temperature?

Tick (✓) **two** boxes.

A

B

C

D

[1]

(ii) Substance **C** is an ionic substance.

Use the information in the table to explain why.

.....

.....

..... [2]

(c) You are provided with a mixture of substances **B** and **C**.

Substance **B** is insoluble in water. Substance **C** is soluble in water.

(i) Describe how you could separate substance **B** from the mixture.

.....  
.....  
.....  
.....  
..... [3]

(ii) Describe how you would then obtain substance **C** after separating substance **B**.

.....  
.....  
..... [2]

GRADEUP.UK

17 Acids are substances that turn universal indicator paper red.

(a) (i) What makes a substance acidic?

..... [1]

(ii) Sodium hydroxide, NaOH, is an alkali.

Sodium hydroxide neutralises sulfuric acid, H<sub>2</sub>SO<sub>4</sub>. The reaction makes a salt called sodium sulfate, Na<sub>2</sub>SO<sub>4</sub>. Water is also made.

Complete the **balanced symbol equation** for this reaction.

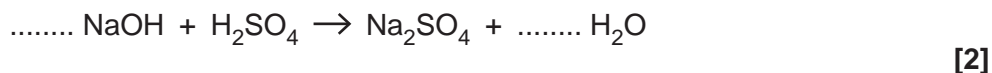

(b) A student investigates the reaction of an aqueous solution of sodium hydroxide and sulfuric acid. During the experiment, the student tests the pH of the solution with universal indicator.

(i) Suggest a piece of equipment that the student could use instead of universal indicator paper to test the pH of the solution.

..... [1]

(ii) Describe how to use the equipment suggested in (b)(i).

.....  
.....  
..... [2]



14  
BLANK PAGE

GRADEUP.UK

PLEASE DO NOT WRITE ON THIS PAGE

18 Electrolysis can be used to separate the elements in some compounds using electricity.

(a) (i) Look at the diagram of an electrolysis experiment.

Complete the diagram using the words in the list.

You may use each word once, more than once or not at all.

**cathode**

**anode**

**battery**

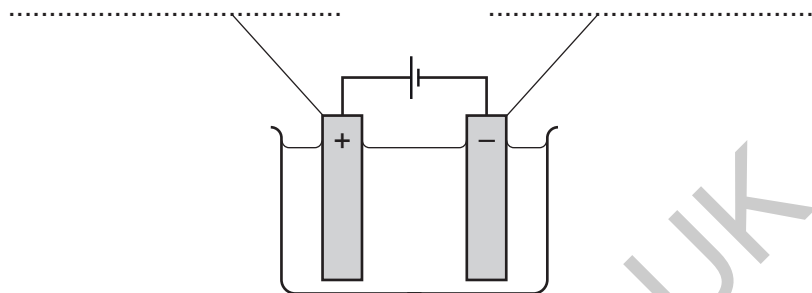

[2]

(ii) A teacher demonstrates the electrolysis of molten lead bromide.

Predict the products made at each electrode.

Positive electrode .....

Negative electrode .....

[2]

(iii) Molten lead bromide contains lead ions,  $\text{Pb}^{2+}$ , and bromide ions,  $\text{Br}^-$ .

What is the formula for lead bromide?

Tick (✓) **one** box.

PbBr

PbBr<sub>2</sub>

Pb<sub>2</sub>Br

Pb<sub>2</sub>Br<sub>2</sub>

[1]

- (b) The student investigates the mass of copper made during the electrolysis of aqueous copper chloride.

The student varies the electric current and passes the current for the same time in each experiment. Here is a table of their results.

Current (A)	Mass of copper produced (g)
0.2	0.6
0.4	1.3
0.6	1.8
0.8	2.5
1.0	3.1

- (i) Plot a graph of the student's results and draw a line of best fit.

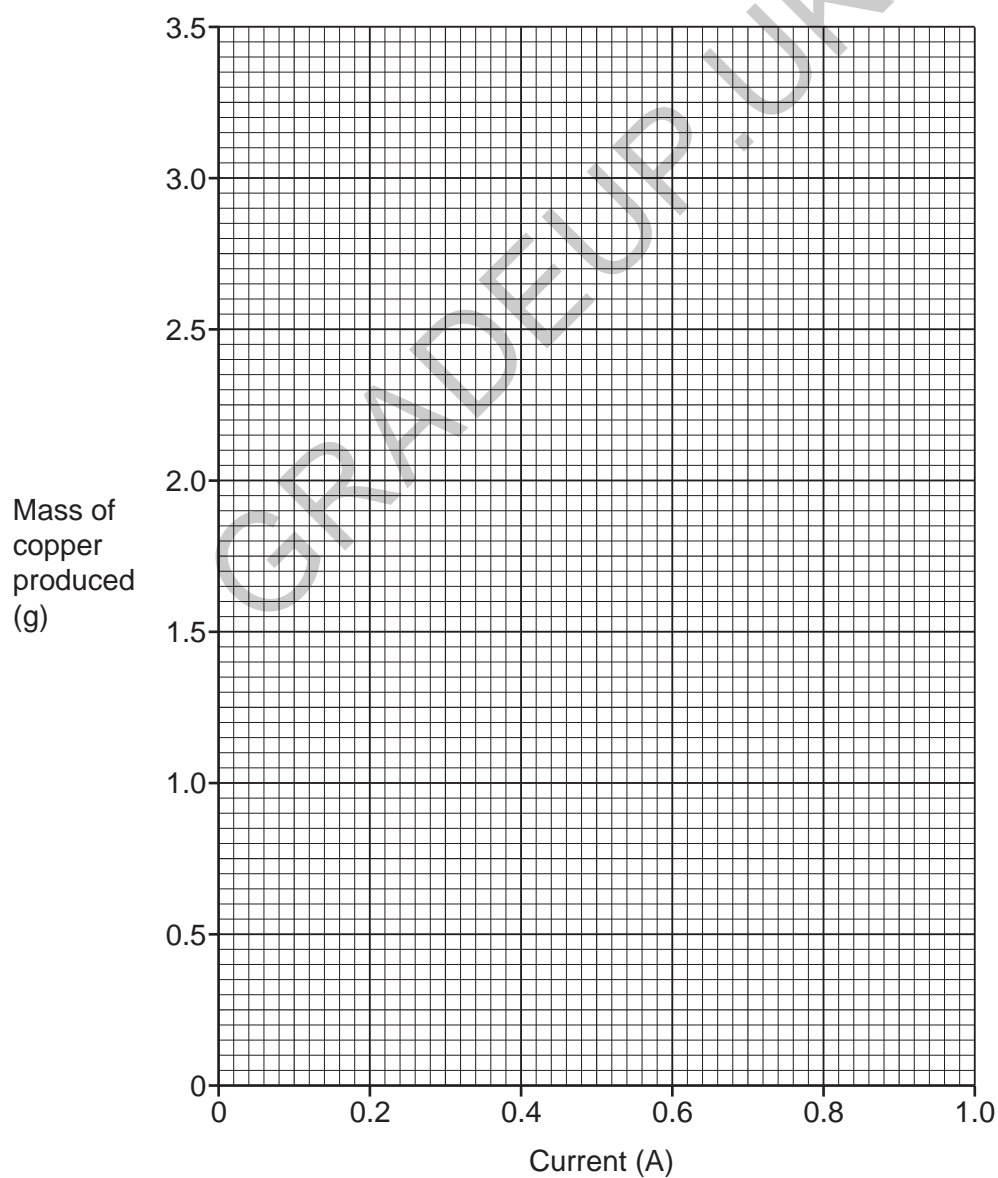

[3]

- (ii) Use your graph to **estimate** the current needed to make 2.25 g of copper.

Current = ..... A [1]

- (iii) Use your graph, and a calculation, to find the mass of copper that would be produced using 15A.

Give your answer to **2** significant figures.

Mass of copper produced = ..... g [2]

- 19 A student investigates the energy changes in different reaction mixtures, X, Y and Z. Fig. 19.1 shows the apparatus she uses.

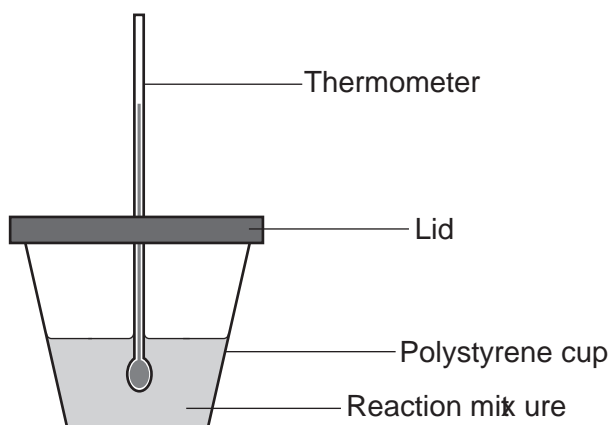

Fig. 19.1

- (a) Look at the table of the student's results.
- (i) Add the temperature change for each reaction mixture. Include a + or – sign where relevant.

Reaction mixture	Temperature at start (°C)	Temperature at end (°C)	Temperature change (°C)
X	20.0	25.5	.....
Y	19.0	8.0	.....
Z	20.0	20.0	.....

[1]

- (ii) Which reaction mixture has an **endothermic** reaction?

Tick (✓) **one** box.

X

Y

Z

Explain your answer.

.....

.....

..... [2]

(iii) Complete the reaction profile for an **endothermic** reaction in **Fig. 19.2**.

The products have already been added.

Label the:

- reactants
- energy change
- activation energy.

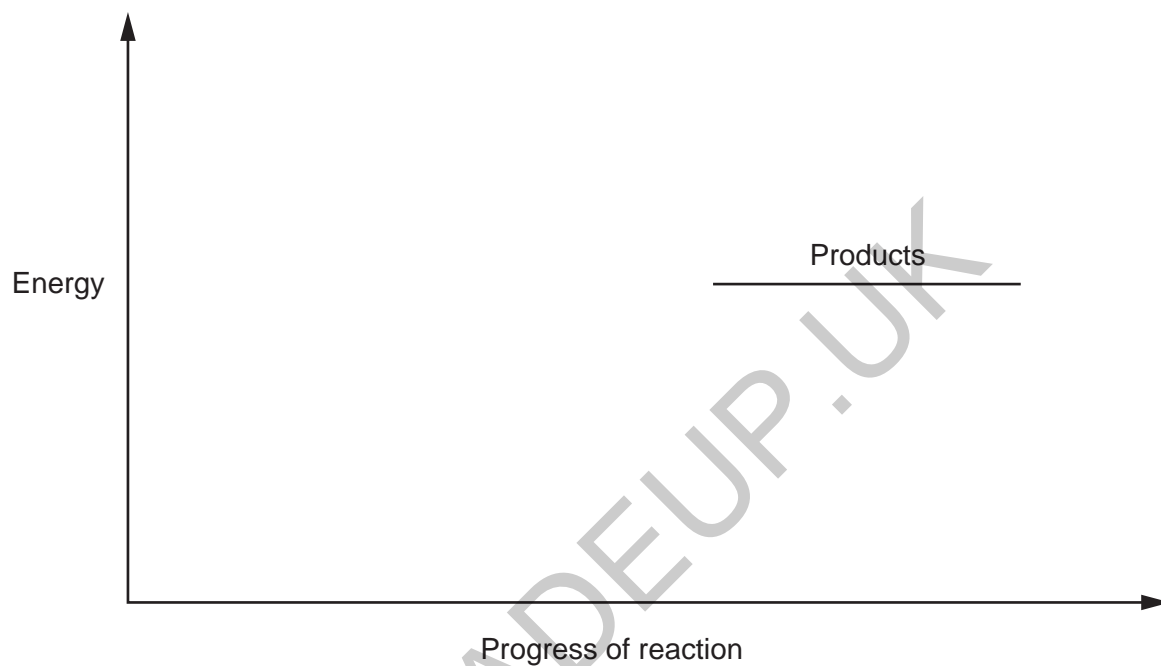

[3]

**Fig. 19.2**

(b) The burning of methane gas is an exothermic reaction.

When methane,  $\text{CH}_4$ , burns in oxygen,  $\text{O}_2$ , carbon dioxide,  $\text{CO}_2$ , and water,  $\text{H}_2\text{O}$ , are made.

Write the **balanced symbol equation** for this reaction.

..... [2]

(c) A student investigates the combustion of ethanol.

Fig. 19.3 shows the apparatus the student uses.

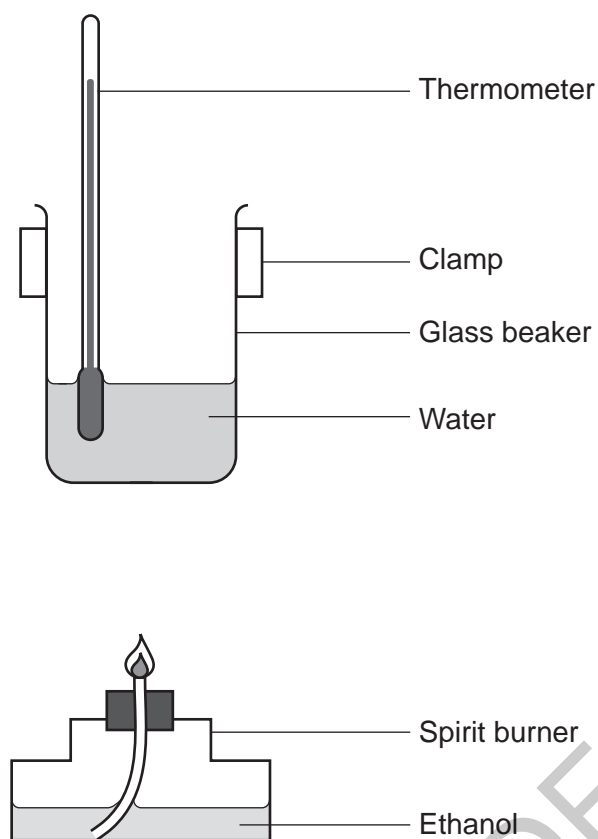

Fig. 19.3

The temperature change is much lower than the textbook value.

Suggest **two** ways that the student could improve the set-up of the apparatus in Fig. 19.3, so the temperature change is closer to the textbook value.

1 .....

.....

2 .....

.....

[2]

21  
BLANK PAGE

PLEASE DO NOT WRITE ON THIS PAGE

GRADEUP.UK

20 A scientist analyses a sample of tomato sauce using chromatography.

The tomato sauce is compared to four known food additives, **A**, **B**, **C** and **D**, as shown in the chromatogram.

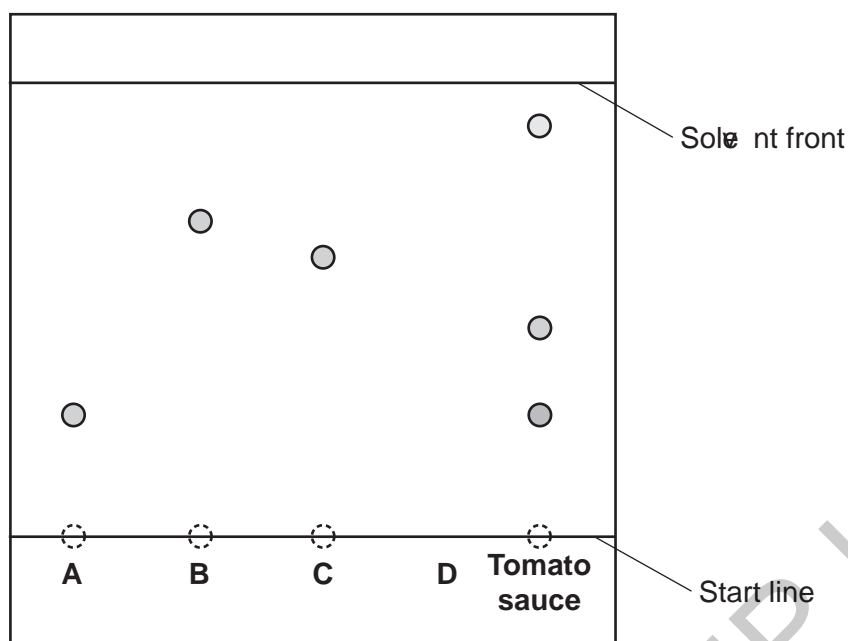

(a) The start line is **not** drawn in ink.

Explain why.

.....  
 ..... [1]

(b) Food additive **D** is insoluble in the solvent used.

**Draw** on the diagram the spot for food additive **D** at the end of the experiment. [1]

(c) Which additive is in the **tomato sauce**?

Tick (✓) **one** box.

**A**

**B**

**C**

[1]

(d) Calculate the  $R_f$  value for additive **C**.

Use the equation:  $R_f = \frac{\text{distance travelled by the substance}}{\text{distance travelled by the solvent}}$

Give your answer to **2** significant figures.

$R_f$  value = ..... [3]

GRADEUP.UK

21 A student is making perfume using violet flowers.

The student does an experiment to extract the perfume from the flowers using the apparatus shown in **Fig. 21.1**.

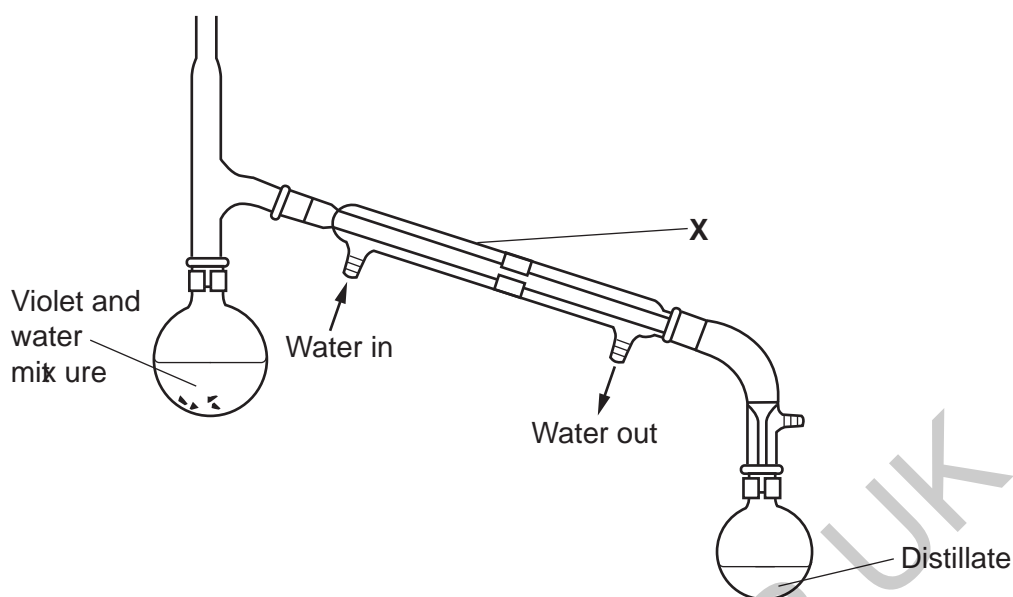

**Fig. 21.1**

(a) The teacher says the apparatus is not set-up correctly.

(i) What is the name of the piece of apparatus labelled **X**?

..... [1]

(ii) Name the process shown in **Fig. 21.1**.

..... [1]

(iii) Suggest **two** changes that the student should make to set-up the apparatus correctly.

1 .....

.....

2 .....

.....

[2]

(b) The student finds out that phosphate fertilisers are used to help to grow flowers.

Compound **A** is a fertiliser of a metal **M** with the formula  $\text{M}_3\text{PO}_4$ .

The relative formula mass of compound **A** is 164.0.

Do a calculation to identify metal **M**.

Use the relative atomic masses in the Periodic Table.

Metal **M** = ..... [3]

22 This question is about structure and bonding.

(a) Look at the two structures, **A** and **B**, in Fig. 22.1.

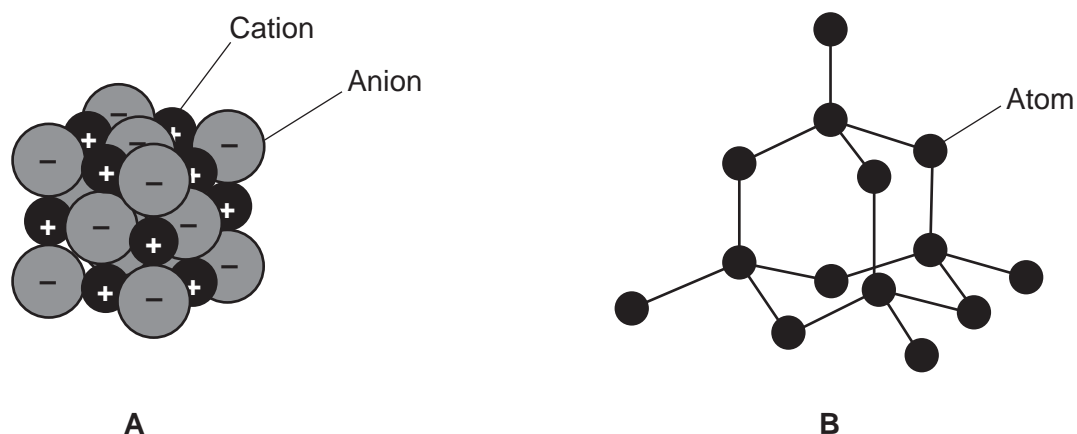

Fig. 22.1

(i) Identify the bonding in structure **A**.

Explain your answer.

Bonding .....

Explanation .....

[2]

(ii) Explain why structure **B** has a high melting point.

.....

.....

[2]

(iii) Explain why structure **B** does **not** conduct electricity.

.....

..... [1]

- (b) Look at the structure of a metal in **Fig. 22.2**. Metals are malleable, which means they can be hammered or pressed into shape without breaking or cracking.

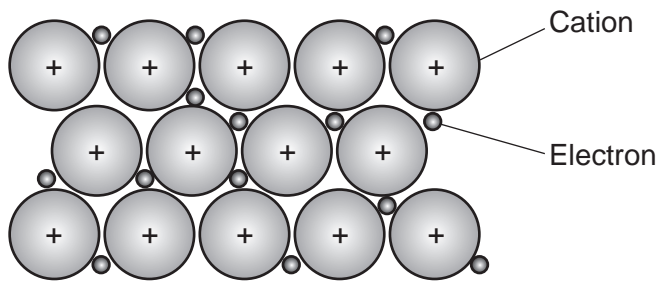

**Fig. 22.2**

Explain why metals are **malleable**.

.....

.....

..... [2]

GRADEUP.UK

28  
BLANK PAGE

GRADEUP.UK

PLEASE DO NOT WRITE ON THIS PAGE

- 23 Dmitri Mendeleev produced a Periodic Table of elements which is the basis for our modern Periodic Table. He left gaps for elements that had not been discovered yet as shown in **Fig. 23.1**.

I	II	III	IV	V	VI	VII
H						
Li	Be	B	C	N	O	F
Na	Mg	Al	Si	P	S	Cl
K	Ca		Ti	V	Cr	Mn
Cu	Zn			As	Se	Br
Rb	Sr	Y	Zr	Nb	Mo	
Ag	Cd	In	Sn	Sb	Te	I
Ce	Ba	La		Ta	W	
Au	Hg	Tl	Pb	Bi		

Fig. 23.1

- (a) Describe **two** ways Mendeleev arranged the elements in his Periodic Table.

1 .....

.....

2 .....

.....

[2]

- (b) Describe how the elements are arranged in the modern Periodic Table.

.....

..... [1]

- (c) Mendeleev left gaps in his Periodic Table for undiscovered elements. He predicted properties of these elements.

**Table 23.1** shows the predicted properties for one of these elements in one of the gaps.

Mendeleev called this element 'eka-silicon'.

<b>Appearance</b>	Grey metal
<b>Melting point (°C)</b>	Over 800
<b>Relative atomic mass</b>	72
<b>Density (g/cm<sup>3</sup>)</b>	5.5

**Table 23.1**

**Table 23.2** shows some of the elements that were discovered after Mendeleev published his Periodic Table.

	<b>Scandium (Sc)</b>	<b>Gallium (Ga)</b>	<b>Germanium (Ge)</b>	<b>Technetium (Tc)</b>
<b>Appearance</b>	Silver-white metal	Silver-blue metal	♦ Grey-white metal	Grey metal
<b>Melting point (°C)</b>	1541	30	947	2157
<b>Relative atomic mass</b>	45.0	69.7	72.6	98.0
<b>Density (g/cm<sup>3</sup>)</b>	3.0	5.9	5.35	11.0

**Table 23.2**

- (i) Which element matches Mendeleev's predictions for 'eka-silicon'?

Tick (✓) **one** box.

Scandium

Gallium

Germanium

Technetium

[1]

(ii) Give **two** reasons for your answer to (c)(i).

1 .....

.....

2 .....

.....

[2]

(d) (i) Mendeleev did not predict the existence of argon, neon, krypton or xenon.

The electron arrangement of argon is 2,8,8.

What does this tell you about the reactivity of argon?

Explain your answer.

.....

.....

..... [2]

(ii) Neon is an element that has isotopes. Two of the isotopes are shown below.



Complete **Table 23.3** to show the number of protons, neutrons and electrons in each neon isotope.

	${}_{10}^{20}\text{Ne}$	${}_{10}^{22}\text{Ne}$
<b>Proton</b>		
<b>Neutron</b>		
<b>Electron</b>		

Table 23.3

[3]

END OF QUESTION PAPER

ADDITIONAL ANSWER SPACE

If additional space is required, you should use the following lined page(s). The question number(s) must be clearly shown in the margin(s).

Lined area for writing answers, featuring horizontal dotted lines and a vertical solid line on the left side. A large watermark 'GRADEUP.UK' is visible diagonally across the page.



Oxford Cambridge and RSA

**Copyright Information**

OCR is committed to seeking permission to reproduce all third-party content that it uses in its assessment materials. OCR has attempted to identify and contact all copyright holders whose work is used in this paper. To avoid the issue of disclosure of answer-related information to candidates, all copyright acknowledgements are reproduced in the OCR Copyright Acknowledgements Booklet. This is produced for each series of examinations and is freely available to download from our public website ([www.ocr.org.uk](http://www.ocr.org.uk)) after the live examination series.

If OCR has unwittingly failed to correctly acknowledge or clear any third-party content in this assessment material, OCR will be happy to correct its mistake at the earliest possible opportunity.

For queries or further information please contact The OCR Copyright Team, The Triangle Building, Shaftesbury Road, Cambridge CB2 8EA.

OCR is part of the Cambridge Assessment Group; Cambridge Assessment is the brand name of University of Cambridge Local Examinations Syndicate (UCLES), which is itself a department of the University of Cambridge.