

Please check the examination details below before entering your candidate information

Candidate surname

Other names

Centre Number

Candidate Number

**Pearson Edexcel Level 1/Level 2 GCSE (9–1)**

**Monday 13 November 2023**

Morning (Time: 1 hour 30 minutes)

Paper  
reference

**1MA1/3F**

**Mathematics**

**PAPER 3 (Calculator)**

**Foundation Tier**



**You must have:** Ruler graduated in centimetres and millimetres, protractor, pair of compasses, pen, HB pencil, eraser, calculator, Formulae Sheet (enclosed). Tracing paper may be used.

Total Marks

### Instructions

- Use **black** ink or ball-point pen.
- **Fill in the boxes** at the top of this page with your name, centre number and candidate number.
- Answer **all** questions.
- Answer the questions in the spaces provided – *there may be more space than you need.*
- You must **show all your working**.
- Diagrams are **NOT** accurately drawn, unless otherwise indicated.
- **Calculators may be used.**
- If your calculator does not have a  $\pi$  button, take the value of  $\pi$  to be 3.142 unless the question instructs otherwise.

### Information

- The total mark for this paper is 80
- The marks for **each** question are shown in brackets – *use this as a guide as to how much time to spend on each question.*

### Advice

- Read each question carefully before you start to answer it.
- Try to answer every question.
- Check your answers if you have time at the end.

Turn over ►

P69532A

©2023 Pearson Education Ltd.  
Z:1/1/1/



P 6 9 5 3 2 A 0 1 2 0



Pearson

Answer ALL questions.

Write your answers in the spaces provided.

You must write down all the stages in your working.

1 Write 35% as a decimal.

.....

(Total for Question 1 is 1 mark)

2 Write 8061 correct to the nearest hundred.

.....

(Total for Question 2 is 1 mark)

3 Write down a number that is less than  $-5$

.....

(Total for Question 3 is 1 mark)

4 Here is a grid of squares.

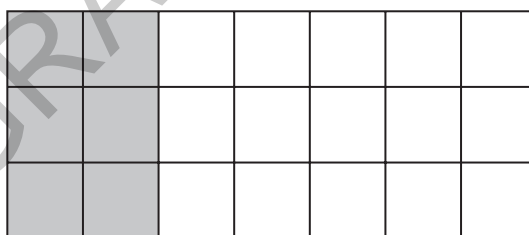

What fraction of the grid is shaded?

.....

(Total for Question 4 is 1 mark)

5 Write down the value of the 9 in the number 27.963

.....

(Total for Question 5 is 1 mark)

DO NOT WRITE IN THIS AREA

DO NOT WRITE IN THIS AREA

DO NOT WRITE IN THIS AREA

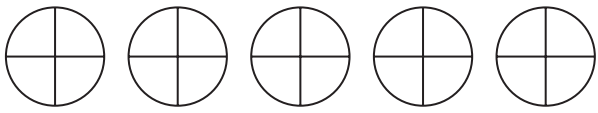
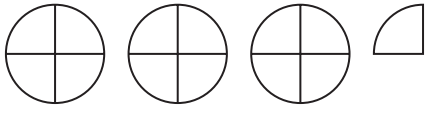
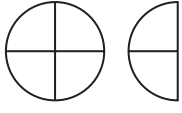

- 6 The pictogram shows information about the number of chocolate cakes, vanilla cakes and lemon cakes sold by Year 7 at a school fair.

Chocolate	
Vanilla	
Lemon	
Banana	

Key:

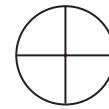

represents 12 cakes

24 banana cakes were sold by Year 7

- (a) Use this information to complete the pictogram.

(1)

At the fair, Year 8 sold a total of 150 cakes.

- (b) Which Year sold most cakes at the fair, Year 7 or Year 8?  
You must show how you get your answer.

(3)

(Total for Question 6 is 4 marks)



- 7 Miklos is swimming lengths of a swimming pool.  
Each length of the pool is 25 m.

Miklos has swum 178 lengths of the pool.  
He wants to swim a total distance of 8050 m.

Calculate how many more lengths Miklos needs to swim.

(Total for Question 7 is 3 marks)

- 8 Here are the first four terms of a number sequence.

97                      91                      85                      79

- (a) Explain how to work out the next number of the sequence.

(1)

- (b) Work out the difference between the 5th term and the 7th term of the sequence.

(2)

- (c) Explain why 52 is **not** a number in this sequence.

(1)

(Total for Question 8 is 4 marks)



DO NOT WRITE IN THIS AREA

DO NOT WRITE IN THIS AREA

DO NOT WRITE IN THIS AREA

9 Mandy buys a 12 kilogram bag of dog food.

Mandy's dog has 3 meals a day.  
She gives her dog 105 grams of dog food for each of these meals.

How many complete weeks will the bag of dog food last?  
You must show all your working.

GRADEUP.UK

.....  
(Total for Question 9 is 5 marks)



10 Here is a polygon.

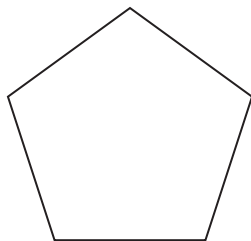

(a) Write down the mathematical name of this polygon.

.....  
(1)

Here is a prism.

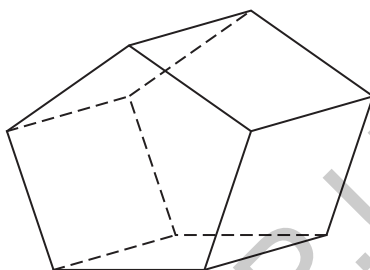

Each edge of the prism has a length of 7.5 cm.

(b) Work out the total length of the edges of the prism.

..... cm  
(2)

(Total for Question 10 is 3 marks)

11 There are only red counters, blue counters and green counters in a bag.

number of red counters : number of blue counters : number of green counters = 2 : 16 : 7

What fraction of the counters in the bag are green counters?

.....  
(Total for Question 11 is 2 marks)



DO NOT WRITE IN THIS AREA

DO NOT WRITE IN THIS AREA

DO NOT WRITE IN THIS AREA

12 A chess match lasted  $3\frac{1}{4}$  hours.

The match finished at 14 10

At what time did the chess match start?

.....

(Total for Question 12 is 2 marks)

13 (a) Simplify  $8h^3 + 14h^3 - 2h^3$

.....  
(1)

(b) Simplify  $(9y + 12y) \div 3$

.....  
(1)

(Total for Question 13 is 2 marks)

14 Write the following numbers in order of size.  
Start with the smallest number.

$\frac{7}{12}$

0.56

57%

$\frac{6}{11}$

0.558

.....

(Total for Question 14 is 2 marks)



- 15 A travel agent sold 100 holidays in April.  
Each of these holidays was in the UK or was abroad.

64 of the 100 holidays were sold to families.  
The rest of the holidays were sold to couples.

11 of the 18 holidays abroad were sold to couples.

- (a) Use this information to complete the frequency tree.

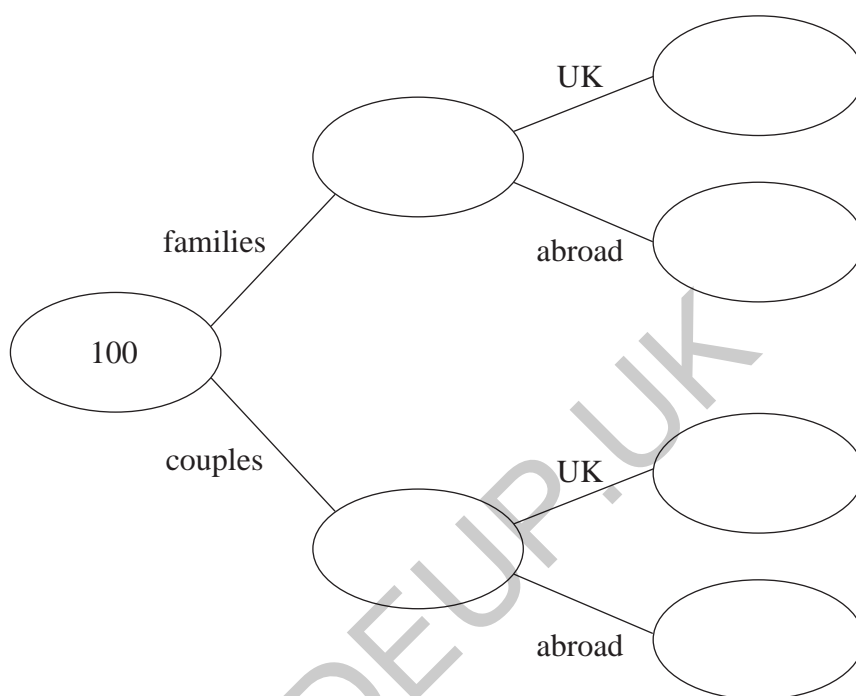

(3)

One of the holidays sold to a family is chosen at random.

- (b) Find the probability that this holiday was **not** abroad.

(2)

(Total for Question 15 is 5 marks)



16 Solve  $\frac{x}{7} + 9 = 4$

$x = \dots\dots\dots$

(Total for Question 16 is 2 marks)

17 Blake works 32 hours a week in the UK.  
She is paid £473.28 per week.

Blake applies for a job in Australia.  
The rate of pay is 26.40 Australian dollars per hour.

£1 = 1.796 Australian dollars

Blake thinks the rate of pay in Australia is greater than the rate of pay in the UK.

Is Blake correct?  
You must show how you get your answer.

GRADEUP.UK

(Total for Question 17 is 3 marks)



18 Here is a shape made from a rectangle and a triangle.

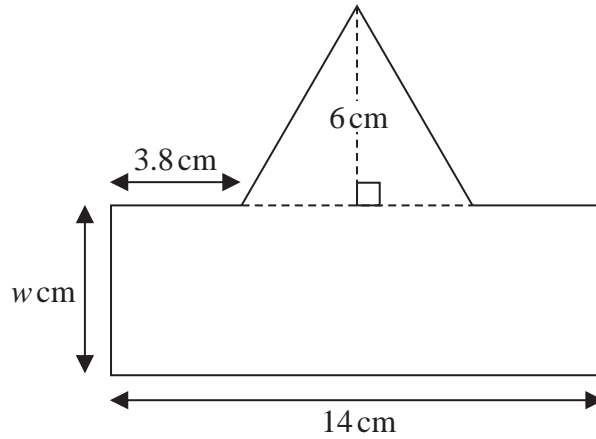

The shape has exactly one line of symmetry.

The area of the rectangle is 3.5 times the area of the triangle.  
The width of the rectangle is  $w$  cm.

Work out the value of  $w$ .  
You must show all your working.

GRADEUP.UK

$w = \dots\dots\dots$

(Total for Question 18 is 5 marks)

DO NOT WRITE IN THIS AREA

DO NOT WRITE IN THIS AREA

DO NOT WRITE IN THIS AREA



19 The front elevation of a cuboid is shown on the centimetre grid below.

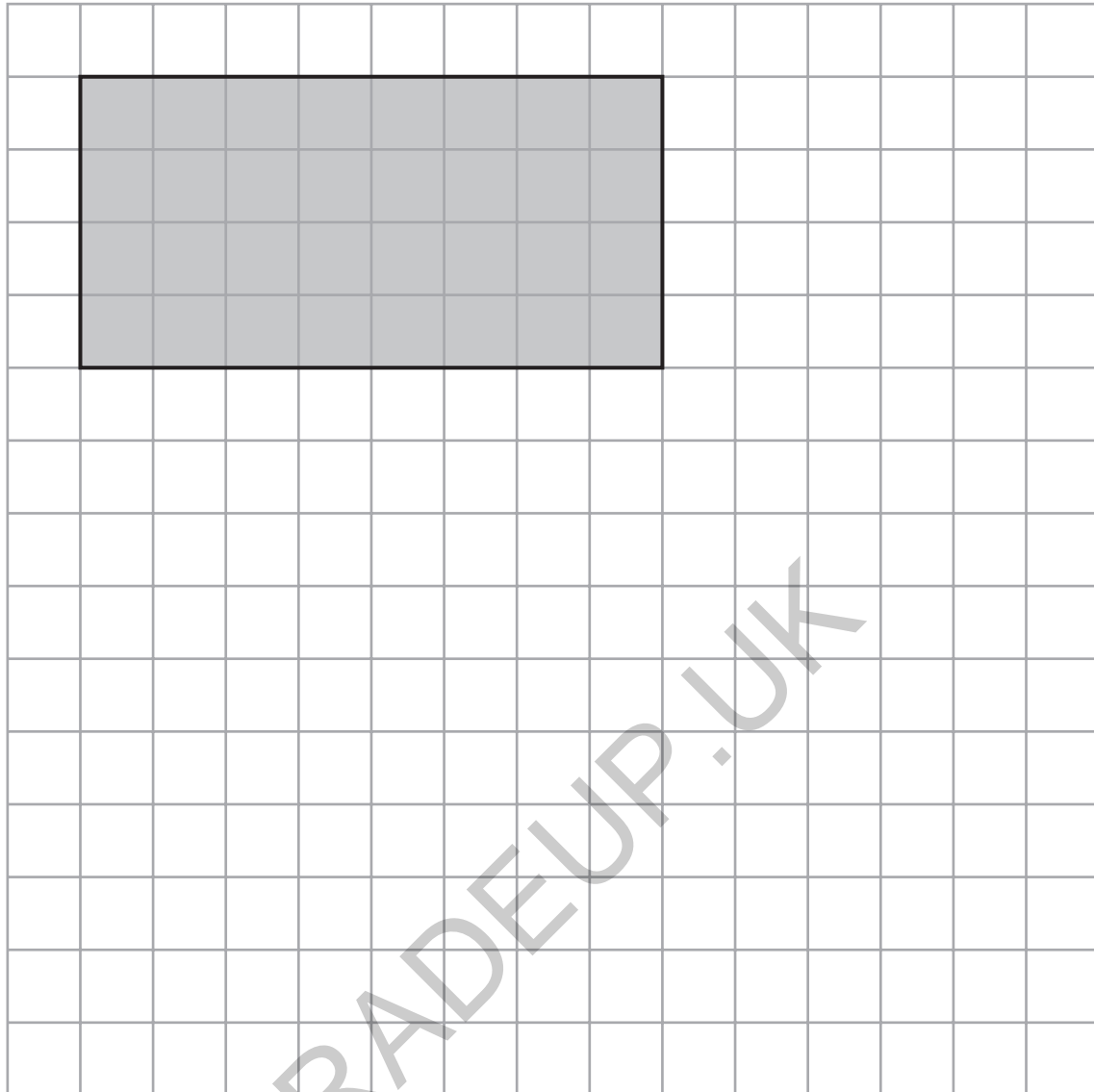

The volume of the cuboid is  $224 \text{ cm}^3$

On the grid, draw the plan of the cuboid.

(Total for Question 19 is 3 marks)



20 (a) Write 468 000 in standard form.

.....  
(1)

(b) Write  $5.037 \times 10^{-4}$  as an ordinary number.

.....  
(1)

(Total for Question 20 is 2 marks)

21 Here is a biased spinner.

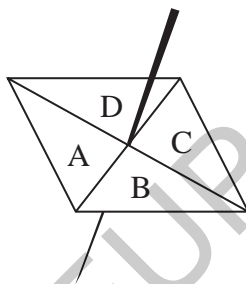

The table shows the probabilities that when the spinner is spun it will land on A, on B, on C and on D.

<b>Letter</b>	A	B	C	D
<b>Probability</b>	0.4	0.21	0.32	0.07

Luka will spin the spinner 200 times.

Work out an estimate for the number of times the spinner will land on A.

.....  
(Total for Question 21 is 2 marks)



DO NOT WRITE IN THIS AREA

DO NOT WRITE IN THIS AREA

DO NOT WRITE IN THIS AREA

22 Seija works at a weather station.

The table gives information about the temperature,  $T$  °C, at midday for each of 50 cities in the UK on Tuesday.

Temperature ( $T$ °C)	Frequency
$10 < T \leq 15$	2
$15 < T \leq 20$	8
$20 < T \leq 25$	13
$25 < T \leq 30$	21
$30 < T \leq 35$	6

(a) Calculate an estimate for the mean temperature.

GRADEUP.UK

..... °C  
(3)

Seija says,

“The median temperature is 22.5 °C because 22.5 is the middle number in the middle group.”

(b) Is Seija correct?

Give a reason for your answer.

.....  
.....  
.....

(1)

(Total for Question 22 is 4 marks)



P 6 9 5 3 2 A 0 1 3 2 0

23 Jenna is asked to show the inequality  $-3 < x \leq 4$  on a number line.

Here is her answer.

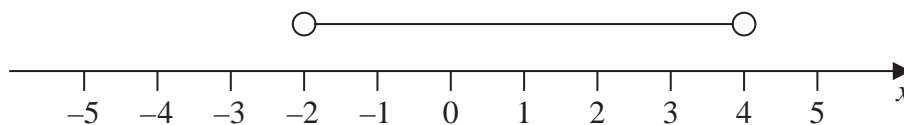

(a) Write down two mistakes Jenna has made.

1.....

.....

2.....

.....

(2)

(b) Work out the greatest integer that satisfies the inequality

$$5y - 7 < 16$$

.....

(2)

(Total for Question 23 is 4 marks)



DO NOT WRITE IN THIS AREA

DO NOT WRITE IN THIS AREA

DO NOT WRITE IN THIS AREA

24 Ali buys packs of balloons and boxes of pencils.

There are 30 balloons in each pack.

There are 24 pencils in each box.

Ali buys exactly the same number of balloons and pencils.

Work out how many packs of balloons and how many boxes of pencils she could have bought.

You must show all your working.

..... packs of balloons

..... boxes of pencils

**(Total for Question 24 is 3 marks)**

25 A company orders a large number of plates from a factory.

It would take 30 hours to make all the plates using 4 machines.

How many machines are needed to make all the plates in 6 hours?

.....  
**(Total for Question 25 is 2 marks)**



26 Riley travelled by car and by aeroplane.

He travelled 143 miles by car at an average speed of 55 miles per hour.  
Riley then travelled for 5 hours and 20 minutes by aeroplane.

Work out, in hours and minutes, Riley's total travelling time.

..... hours ..... minutes

(Total for Question 26 is 3 marks)

GRADEUP.UK

DO NOT WRITE IN THIS AREA

DO NOT WRITE IN THIS AREA

DO NOT WRITE IN THIS AREA



DO NOT WRITE IN THIS AREA

DO NOT WRITE IN THIS AREA

DO NOT WRITE IN THIS AREA

27 The diagram shows a solid cube placed on a horizontal table.

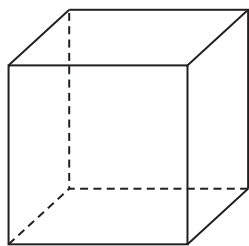

$$\text{pressure} = \frac{\text{force}}{\text{area}}$$

The pressure on the table due to the cube is  $3.5 \text{ newtons/cm}^2$

The force exerted by the cube on the table is 504 newtons.

Show that the total surface area of the cube is less than  $900 \text{ cm}^2$

GRADEUP.UK

(Total for Question 27 is 3 marks)



28 The line **L** is shown on the grid.

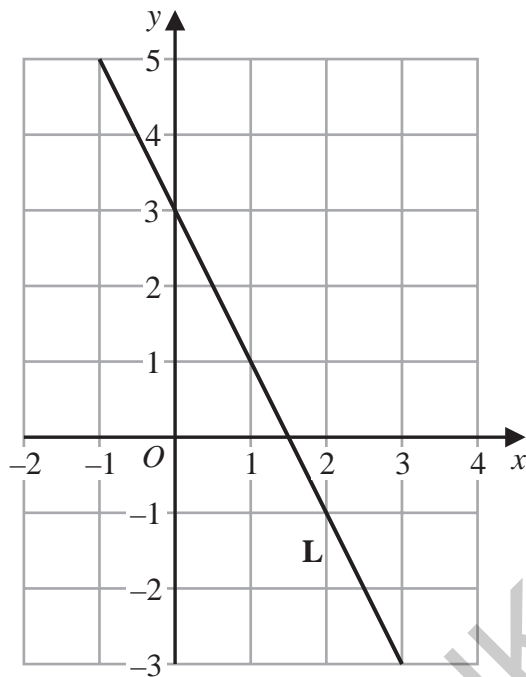

Find an equation for **L**.

.....  
(Total for Question 28 is 3 marks)

DO NOT WRITE IN THIS AREA

DO NOT WRITE IN THIS AREA

DO NOT WRITE IN THIS AREA



DO NOT WRITE IN THIS AREA

DO NOT WRITE IN THIS AREA

DO NOT WRITE IN THIS AREA

29  $A, B, C$  and  $D$  are points on a circle such that  $ABCD$  is a square.

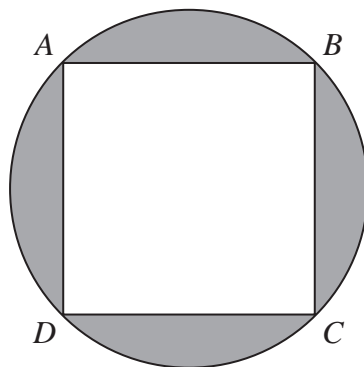

The square  $ABCD$  has sides of length 3.5 cm.

Calculate the circumference of the circle.  
Give your answer correct to 1 decimal place.  
You must show all your working.

GRADEUP.UK

..... cm

(Total for Question 29 is 4 marks)

TOTAL FOR PAPER IS 80 MARKS



P 6 9 5 3 2 A 0 1 9 2 0

DO NOT WRITE IN THIS AREA

DO NOT WRITE IN THIS AREA

DO NOT WRITE IN THIS AREA

GRADEUP.UK

**BLANK PAGE**



# Pearson Edexcel GCSE (9–1) Mathematics

Monday 13 November 2023 – Morning

Syllabus  
reference

**1MA1/3F**

## Mathematics

**PAPER 3 (Calculator)**

**Foundation Tier**

**Formulae Sheet**

**Do not return this Sheet with the question paper.**

GRADEUP.UK

Turn over ►

P69532A

©2023 Pearson Education Ltd.

1/1/1



P 6 9 5 3 2 A



Pearson

## Foundation Tier Formulae Sheet

### Perimeter, area and volume

Where  $a$  and  $b$  are the lengths of the parallel sides and  $h$  is their perpendicular separation:

$$\text{Area of a trapezium} = \frac{1}{2} (a + b) h$$

Volume of a prism = area of cross section  $\times$  length

Where  $r$  is the radius and  $d$  is the diameter:

$$\text{Circumference of a circle} = 2\pi r = \pi d$$

$$\text{Area of a circle} = \pi r^2$$

### Pythagoras' Theorem and Trigonometry

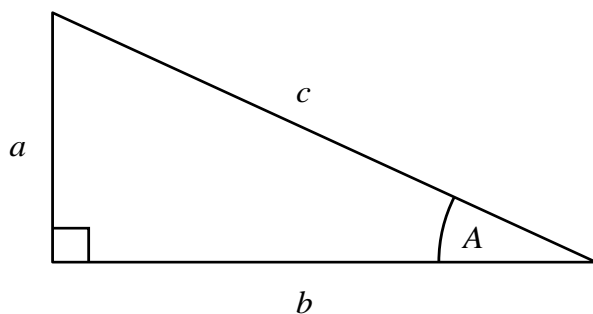

In any right-angled triangle where  $a$ ,  $b$  and  $c$  are the length of the sides and  $c$  is the hypotenuse:

$$a^2 + b^2 = c^2$$

In any right-angled triangle  $ABC$  where  $a$ ,  $b$  and  $c$  are the length of the sides and  $c$  is the hypotenuse:

$$\sin A = \frac{a}{c} \quad \cos A = \frac{b}{c} \quad \tan A = \frac{a}{b}$$

### Compound Interest

Where  $P$  is the principal amount,  $r$  is the interest rate over a given period and  $n$  is number of times that the interest is compounded:

$$\text{Total accrued} = P \left( 1 + \frac{r}{100} \right)^n$$

### Probability

Where  $P(A)$  is the probability of outcome  $A$  and  $P(B)$  is the probability of outcome  $B$ :

$$P(A \text{ or } B) = P(A) + P(B) - P(A \text{ and } B)$$

**END OF EXAM AID**