

Please check the examination details below before entering your candidate information

Candidate surname

Other names

Centre Number

Candidate Number

--	--	--	--	--

--	--	--	--

Pearson Edexcel Level 1/Level 2 GCSE (9–1)

Friday 10 November 2023

Morning (Time: 1 hour 30 minutes)

Paper
reference

1MA1/2H

Mathematics
PAPER 2 (Calculator)
Higher Tier



You must have: Ruler graduated in centimetres and millimetres, protractor, pair of compasses, pen, HB pencil, eraser, calculator, Formulae Sheet (enclosed). Tracing paper may be used.

Total Marks

Instructions

- Use **black** ink or ball-point pen.
- **Fill in the boxes** at the top of this page with your name, centre number and candidate number.
- Answer **all** questions.
- Answer the questions in the spaces provided – *there may be more space than you need.*
- You must **show all your working**.
- Diagrams are **NOT** accurately drawn, unless otherwise indicated.
- **Calculators may be used.**
- If your calculator does not have a π button, take the value of π to be 3.142 unless the question instructs otherwise.

Information

- The total mark for this paper is 80
- The marks for **each** question are shown in brackets – *use this as a guide as to how much time to spend on each question.*

Advice

- Read each question carefully before you start to answer it.
- Try to answer every question.
- Check your answers if you have time at the end.

Turn over ►

P69534A

©2023 Pearson Education Ltd.
Z:1/1/1/1/



Answer ALL questions.

Write your answers in the spaces provided.

You must write down all the stages in your working.

1 (a) Expand and simplify $3(2y - 5) + 7(y + 2)$

.....
(2)

(b) Factorise fully $6x^2 + 15x$

.....
(2)

(c) Make g the subject of the formula $f = 3g + 11$

.....
(2)

(Total for Question 1 is 6 marks)

DO NOT WRITE IN THIS AREA

DO NOT WRITE IN THIS AREA

DO NOT WRITE IN THIS AREA



DO NOT WRITE IN THIS AREA

DO NOT WRITE IN THIS AREA

DO NOT WRITE IN THIS AREA

2 Karen is organising a party for a charity.

She spends

£100 on food

£120 on a hall

£80 on a DJ.

Karen sells 54 tickets for the party.

Each ticket costs £7.50

Work out the percentage profit Karen makes for the charity.

GRADEUP.UK

.....%

(Total for Question 2 is 4 marks)



- 3 Andrew invests £4500 in a savings account for 2 years.
The account pays compound interest at a rate of 3.4% per year.

Calculate how much Andrew has in this savings account at the end of the 2 years.

£.....

(Total for Question 3 is 2 marks)

- 4 Solve $5x - 14 = 52 - x$

$x =$

(Total for Question 4 is 3 marks)



DO NOT WRITE IN THIS AREA

DO NOT WRITE IN THIS AREA

DO NOT WRITE IN THIS AREA

- 5 Chris, Debbie and Errol share some money in the ratio 3 : 4 : 2
Debbie gets £120

Chris then gives some of his share to Debbie and some of his share to Errol.
The money that Chris, Debbie and Errol each have is now in the ratio 2 : 5 : 3

How much money did Chris give to Errol?

£.....

(Total for Question 5 is 4 marks)

- 6 The bearing of port *B* from port *A* is 147°
Work out the bearing of port *A* from port *B*.

o

(Total for Question 6 is 2 marks)



- 7 The diagram shows an empty tank in the shape of a cylinder.

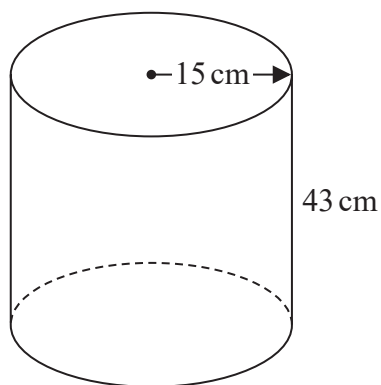

The cylinder has radius 15 cm and height 43 cm.

Water flows into the tank at a rate of 0.47 litres per minute.

Calculate the number of minutes it will take to completely fill the tank.
Give your answer correct to the nearest minute.

GRADEUP.UK

..... minutes

(Total for Question 7 is 4 marks)



DO NOT WRITE IN THIS AREA

DO NOT WRITE IN THIS AREA

DO NOT WRITE IN THIS AREA

8 A number x is written correct to 2 significant figures.

The result is 1.9

Complete the error interval for x .

..... $\leq x <$

(Total for Question 8 is 2 marks)

9 Expand and simplify $(x + 7)(x - 2)(x + 3)$

GRADEUP.UK

.....

(Total for Question 9 is 3 marks)



- 10 Shakir has to complete two tests.
He can either pass or fail each test.

The probability that he will pass the first test is 0.87

If he passes the first test the probability he will pass the second test is 0.94

If he fails the first test the probability he will pass the second test is 0.73

- (a) Complete the probability tree diagram for this information.

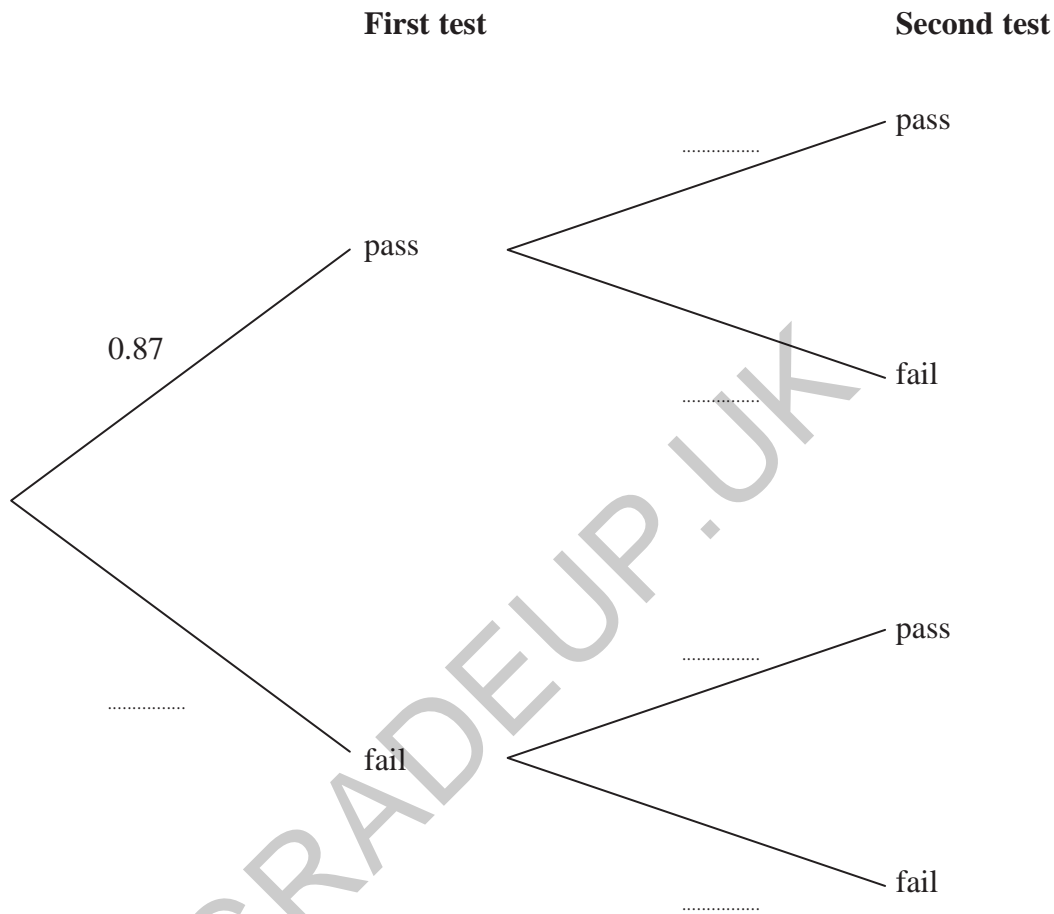

- (b) Work out the probability that Shakir passes at least one of the tests.

.....
(3)

(Total for Question 10 is 5 marks)



11

Graph A

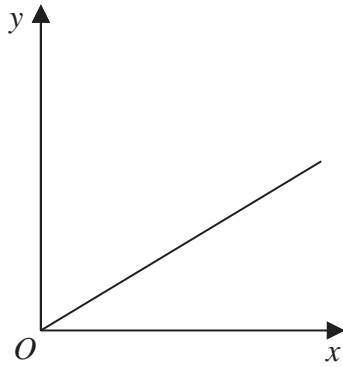

Graph B

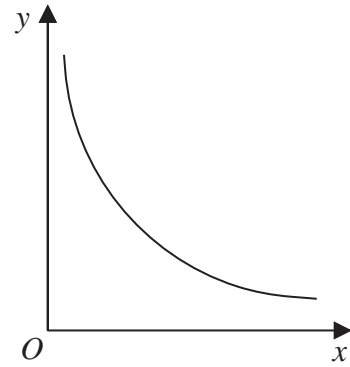

Graph C

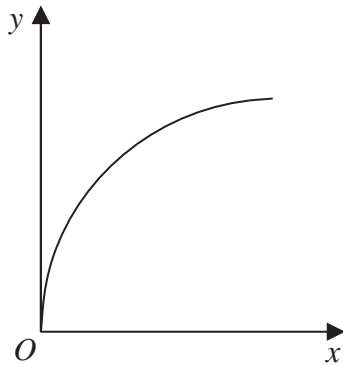

Graph D

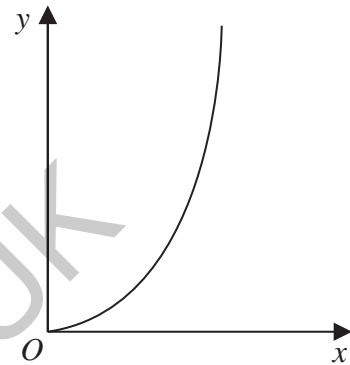

The graphs of y against x represent four different types of proportionality.

Match each type of proportionality in the table to the correct graph.

Type of proportionality	Graph
$y \propto x^2$	
$y \propto x$	
$y \propto \frac{1}{x}$	
$y \propto \sqrt{x}$	

(Total for Question 11 is 2 marks)



- 12** A is the point with coordinates $(7, 13)$
 B is the point with coordinates $(-3, 21)$
 C is the point with coordinates $(15, 23)$

M is the midpoint of AB .
 N is the midpoint of BC .

Work out the distance between M and N .
Give your answer correct to 1 decimal place.

.....
(Total for Question 12 is 3 marks)

DO NOT WRITE IN THIS AREA

DO NOT WRITE IN THIS AREA

DO NOT WRITE IN THIS AREA



13 Prove algebraically that $0.0\dot{7}2\dot{3}$ can be written as $\frac{241}{3330}$

(Total for Question 13 is 3 marks)

14 y is proportional to x^2
 $y = 3$ when $x = 0.5$

x is inversely proportional to w
 $x = 2$ when $w = 0.2$

Find the value of y when $w = 2$

$y = \dots\dots\dots$

(Total for Question 14 is 5 marks)

DO NOT WRITE IN THIS AREA

DO NOT WRITE IN THIS AREA

DO NOT WRITE IN THIS AREA



- 15 The incomplete table and the incomplete histogram give information about the times taken by some students to run a race.

Time (t seconds)	Frequency
$10 < t \leq 12$	
$12 < t \leq 16$	10
$16 < t \leq 19$	15
$19 < t \leq 21$	9
$21 < t \leq 26$	7

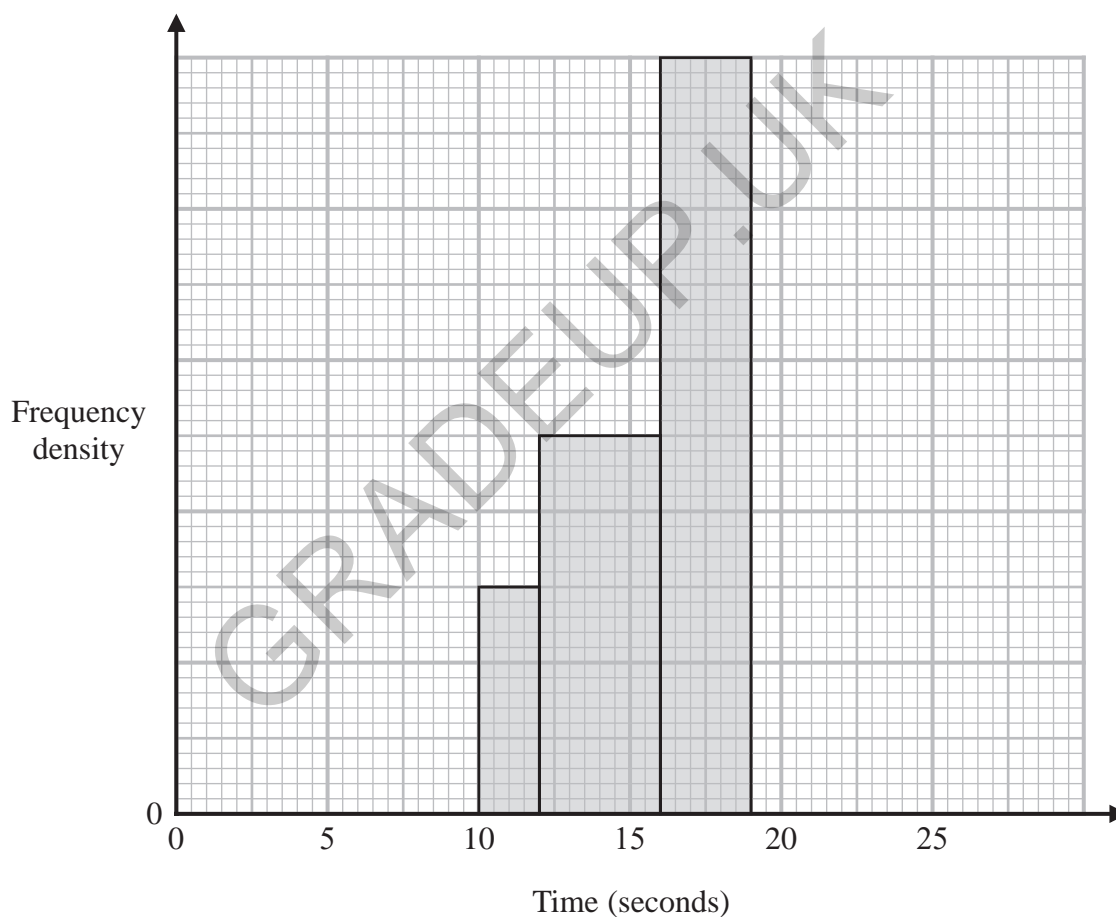

None of these students had a time for the race such that $t \leq 10$ or $t > 26$

- (a) Use the histogram to complete the table.

(1)

- (b) Use the table to complete the histogram.

(2)



The histogram below gives information about the times taken by 43 students to run a different race.

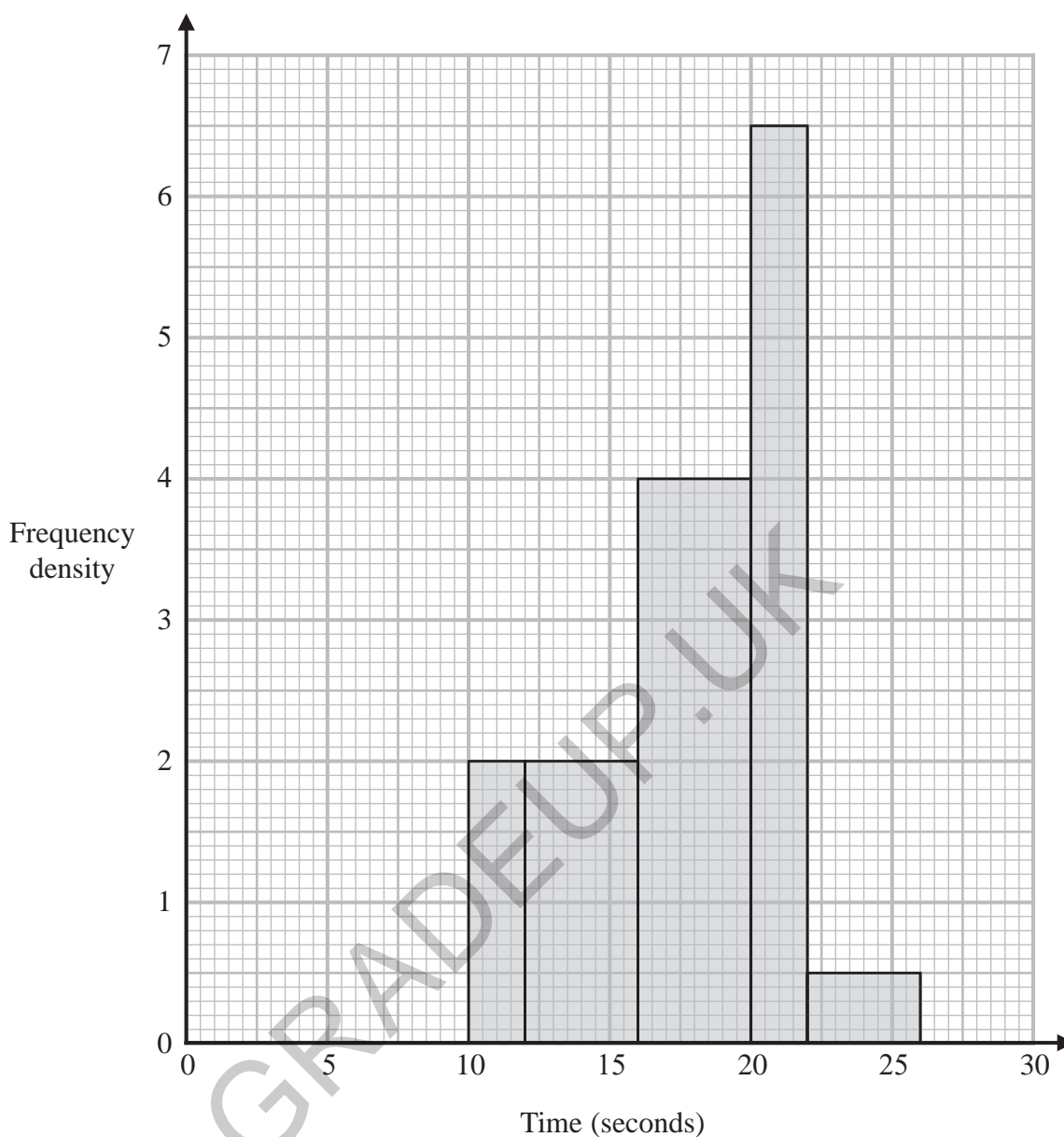

(c) Work out an estimate for the median of the times taken by these 43 students to run the race.

..... seconds

(3)

(Total for Question 15 is 6 marks)



P 6 9 5 3 4 A 0 1 3 2 0

16 $ABCD$ is a trapezium.

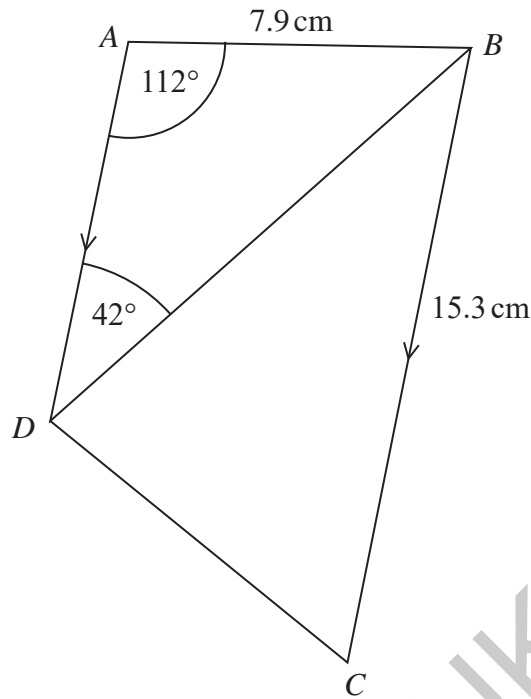

AD is parallel to BC .

Calculate the area of triangle BCD .

Give your answer correct to 1 decimal place.

..... cm^2

(Total for Question 16 is 4 marks)

DO NOT WRITE IN THIS AREA

DO NOT WRITE IN THIS AREA

DO NOT WRITE IN THIS AREA



17 (a) Show that the equation $x^3 + 2x - 6 = 0$ has a solution between $x = 1$ and $x = 2$

(2)

(b) Show that the equation $x^3 + 2x - 6 = 0$ can be rearranged to give $x = \frac{6}{x^2 + 2}$

(1)

(c) Starting with $x_0 = 1.45$

use the iteration formula $x_{n+1} = \frac{6}{x_n^2 + 2}$ twice to find an estimate
for the solution of $x^3 + 2x - 6 = 0$

Give your answer correct to 4 decimal places.

(3)

(Total for Question 17 is 6 marks)



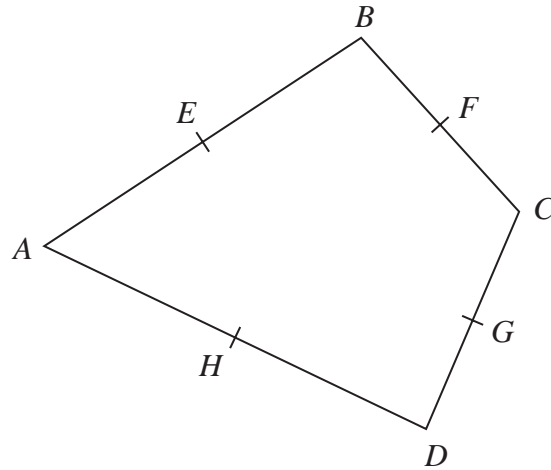

$ABCD$ is a quadrilateral.

E , F , G and H are the midpoints of AB , BC , CD and DA .

$$\vec{AH} = \mathbf{a} \quad \vec{AE} = \mathbf{b} \quad \vec{DG} = \mathbf{c}$$

Prove, using vectors, that $EFGH$ is a parallelogram.

(Total for Question 18 is 4 marks)



19 The functions f and g are such that

$$f(x) = (2x + 3)^2 \quad \text{and} \quad g(x) = 2x - 1$$

(a) Find $gf(-3)$

.....
(2)

(b) Find $g^{-1}(x)$

$$g^{-1}(x) = \text{.....}$$

(2)

(Total for Question 19 is 4 marks)

DO NOT WRITE IN THIS AREA

GRADEUP.UK



P 6 9 5 3 4 A 0 1 7 2 0

20 Write

$\frac{14}{3x-21} + \left[(x+4) \div \frac{2x^2-6x-56}{2x+3} \right]$ in the form $\frac{ax+b}{cx+d}$ where a, b, c and d are integers.

GRADEUP.UK

DO NOT WRITE IN THIS AREA

DO NOT WRITE IN THIS AREA

DO NOT WRITE IN THIS AREA

(Total for Question 20 is 4 marks)



DO NOT WRITE IN THIS AREA

DO NOT WRITE IN THIS AREA

DO NOT WRITE IN THIS AREA

21 Vicky has a collection of medals.

The Venn diagram gives information about the number of medals in her collection where

$$\mathcal{E} = \{\text{all medals}\}$$

$$A = \{\text{English medals}\}$$

$$B = \{\text{gold medals}\}$$

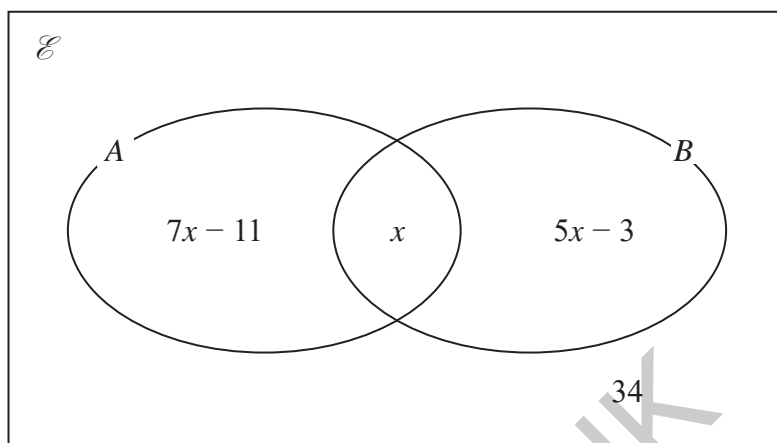

Vicky is going to take at random a medal from her collection.

Given that the medal is gold, the probability that the medal is English is $\frac{2}{11}$

Work out the number of medals in Vicky's collection.

(Total for Question 21 is 4 marks)

TOTAL FOR PAPER IS 80 MARKS



DO NOT WRITE IN THIS AREA

DO NOT WRITE IN THIS AREA

DO NOT WRITE IN THIS AREA

GRADEUP.UK

BLANK PAGE



Pearson Edexcel GCSE (9–1) Mathematics

Friday 10 November 2023 – Morning

Syllabus
reference

1MA1/2H

Mathematics

PAPER 2 (Calculator)

Higher Tier

Formulae Sheet

Do not return this Sheet with the question paper.

GRADEUP.UK

Turn over ►

P69534A

©2023 Pearson Education Ltd.

Z:1/1/1/1/



P 6 9 5 3 4 A

Pearson

Higher Tier Formulae Sheet

Perimeter, area and volume

Where a and b are the lengths of the parallel sides and h is their perpendicular separation:

$$\text{Area of a trapezium} = \frac{1}{2} (a + b) h$$

Volume of a prism = area of cross section \times length

Where r is the radius and d is the diameter:

$$\text{Circumference of a circle} = 2\pi r = \pi d$$

$$\text{Area of a circle} = \pi r^2$$

Quadratic formula

The solution of $ax^2 + bx + c = 0$

where $a \neq 0$

$$x = \frac{-b \pm \sqrt{b^2 - 4ac}}{2a}$$

Pythagoras' Theorem and Trigonometry

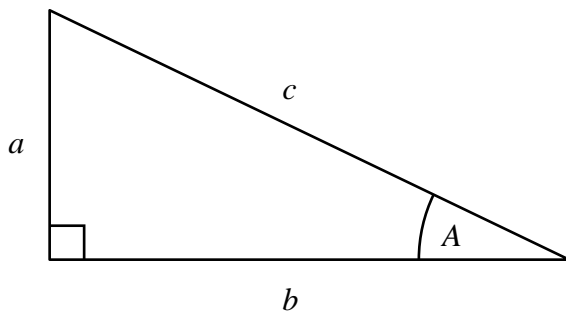

In any right-angled triangle where a , b and c are the length of the sides and c is the hypotenuse:

$$a^2 + b^2 = c^2$$

In any right-angled triangle ABC where a , b and c are the length of the sides and c is the hypotenuse:

$$\sin A = \frac{a}{c} \quad \cos A = \frac{b}{c} \quad \tan A = \frac{a}{b}$$

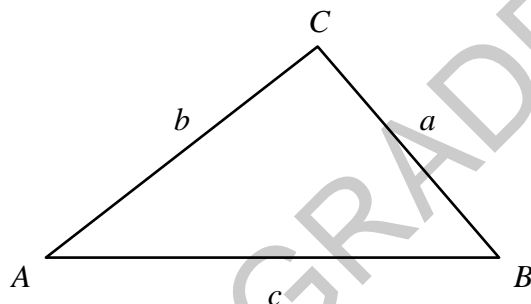

In any triangle ABC where a , b and c are the length of the sides:

$$\text{sine rule: } \frac{a}{\sin A} = \frac{b}{\sin B} = \frac{c}{\sin C}$$

$$\text{cosine rule: } a^2 = b^2 + c^2 - 2bc \cos A$$

$$\text{Area of triangle} = \frac{1}{2} a b \sin C$$

Compound Interest

Where P is the principal amount, r is the interest rate over a given period and n is number of times that the interest is compounded:

$$\text{Total accrued} = P \left(1 + \frac{r}{100} \right)^n$$

Probability

Where $P(A)$ is the probability of outcome A and $P(B)$ is the probability of outcome B :

$$P(A \text{ or } B) = P(A) + P(B) - P(A \text{ and } B)$$

$$P(A \text{ and } B) = P(A \text{ given } B) P(B)$$

END OF EXAM AID

