

Please check the examination details below before entering your candidate information

Candidate surname	Other names
-------------------	-------------

Centre Number	Candidate Number
<input type="text"/> <input type="text"/> <input type="text"/> <input type="text"/> <input type="text"/>	<input type="text"/> <input type="text"/> <input type="text"/> <input type="text"/> <input type="text"/>

## Pearson Edexcel Level 1/Level 2 GCSE (9–1)

Time 1 hour 30 minutes

Paper reference

**1MA1/2H**

### Mathematics PAPER 2 (Calculator) Higher Tier

**You must have:** Ruler graduated in centimetres and millimetres, protractor, pair of compasses, pen, HB pencil, eraser, calculator. Tracing paper may be used.

Total Marks

### Instructions

- Use **black** ink or ball-point pen.
- **Fill in the boxes** at the top of this page with your name, centre number and candidate number.
- Answer **all** questions.
- Answer the questions in the spaces provided – *there may be more space than you need.*
- You must **show all your working**.
- Diagrams are **NOT** accurately drawn, unless otherwise indicated.
- **Calculators may be used.**
- If your calculator does not have a  $\pi$  button, take the value of  $\pi$  to be 3.142 unless the question instructs otherwise.



### Information

- The total mark for this paper is 80
- The marks for **each** question are shown in brackets – *use this as a guide as to how much time to spend on each question.*

### Advice

- Read each question carefully before you start to answer it.
- Try to answer every question.
- Check your answers if you have time at the end.

Turn over ►

P64632A

©2021 Pearson Education Ltd.

E:1/1/1/1/1/1/



Answer ALL questions.

Write your answers in the spaces provided.

You must write down all the stages in your working.

- 1 (a) Write down the inequality shown on this number line.

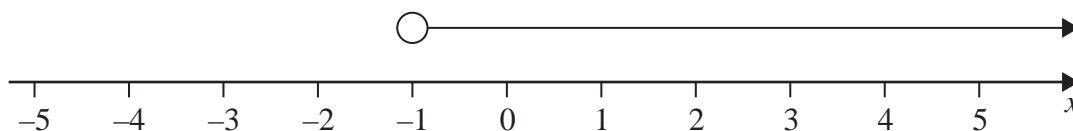

(1)

- (b) On the number line below, show the inequality  $-3 \leq y < 4$



(2)

(Total for Question 1 is 3 marks)

DO NOT WRITE IN THIS AREA

DO NOT WRITE IN THIS AREA

DO NOT WRITE IN THIS AREA



DO NOT WRITE IN THIS AREA

DO NOT WRITE IN THIS AREA

DO NOT WRITE IN THIS AREA

2 (a) Find the Highest Common Factor (HCF) of 60 and 84

.....  
(2)

(b) Find the Lowest Common Multiple (LCM) of 24 and 40

.....  
(2)

(Total for Question 2 is 4 marks)



- 3 Sam drives his car on a journey.  
Here is the travel graph for the first 15 minutes of his journey.

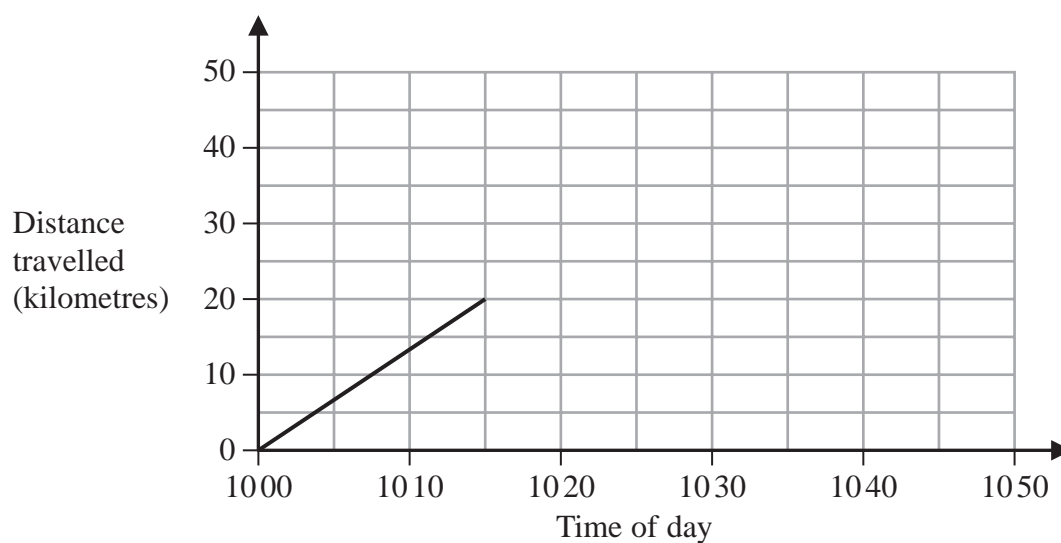

- (a) Work out Sam's speed, in km/h, for the first 15 minutes of his journey.

..... km/h  
(2)

At 1015 Sam stops for 10 minutes and then drives for 20 minutes at a speed of 75 km/h.

- (b) On the grid, complete the travel graph for Sam's journey.

(3)

(Total for Question 3 is 5 marks)



4 (a) Complete the table of values for  $y = x^2 - 2x + 2$

$x$	-2	-1	0	1	2	3	4
$y$	10		2			5	

(2)

(b) On the grid, draw the graph of  $y = x^2 - 2x + 2$  for values of  $x$  from -2 to 4

(2)

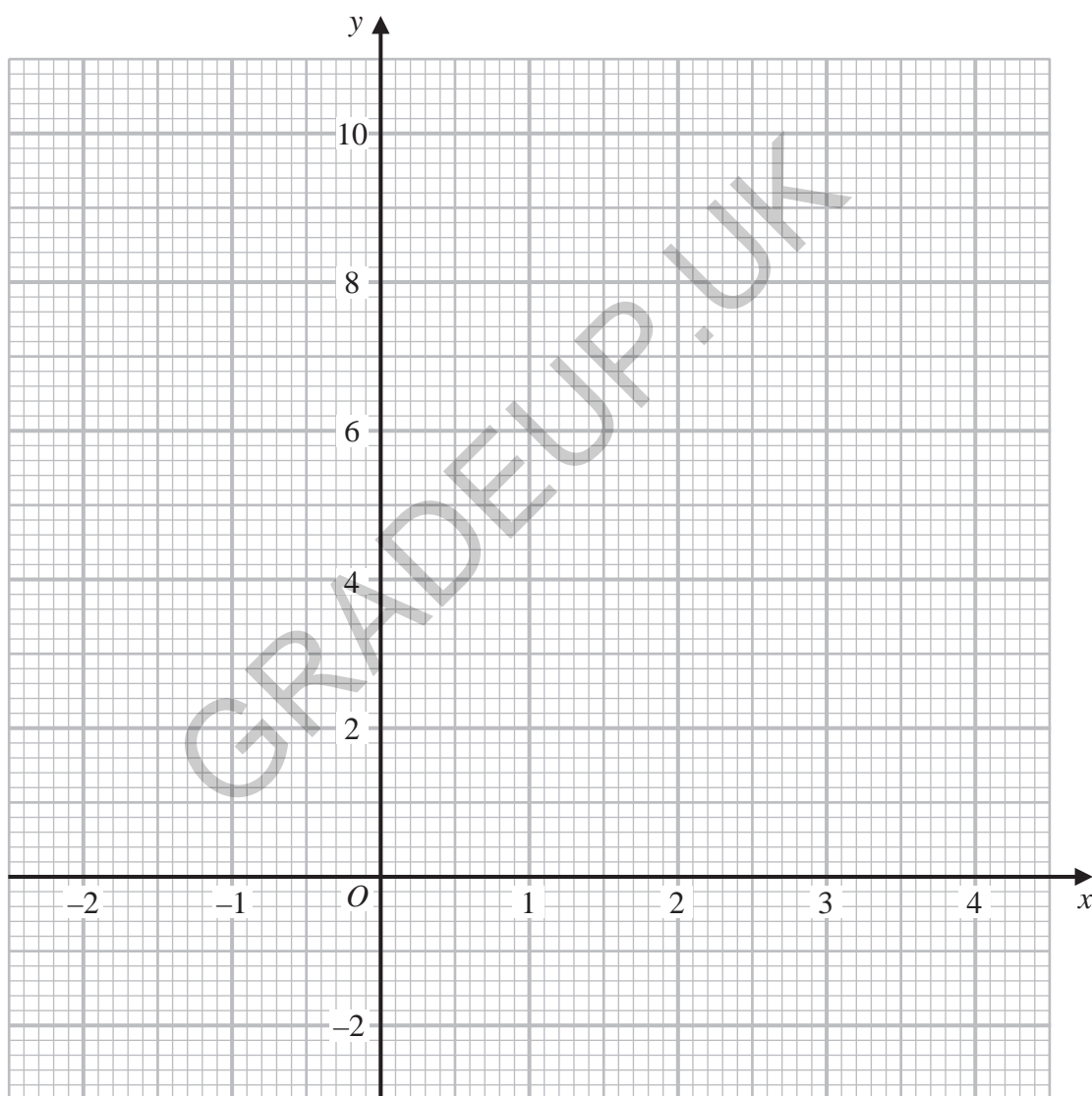

(c) Use your graph to find estimates of the solutions of the equation  $x^2 - 2x + 2 = 4$

(2)

(Total for Question 4 is 6 marks)



P 6 4 6 3 2 A 0 5 2 4

5 Here is a right-angled triangle.

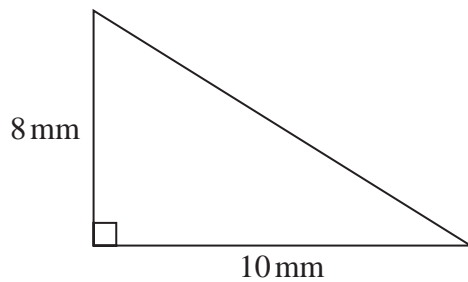

The shaded shape below is made from two of these triangles.

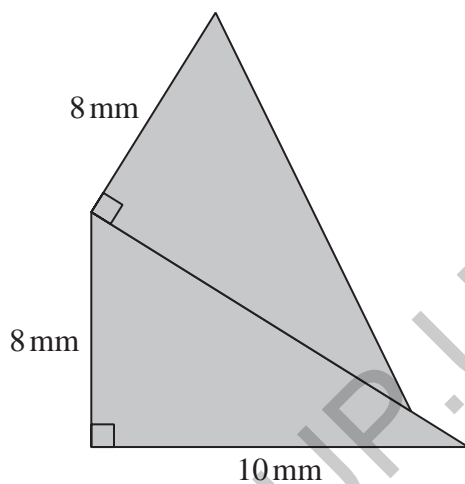

Work out the perimeter of the shaded shape.  
Give your answer correct to 3 significant figures.

..... mm

(Total for Question 5 is 4 marks)



DO NOT WRITE IN THIS AREA

DO NOT WRITE IN THIS AREA

DO NOT WRITE IN THIS AREA

6  $ABC$  is a right-angled triangle.

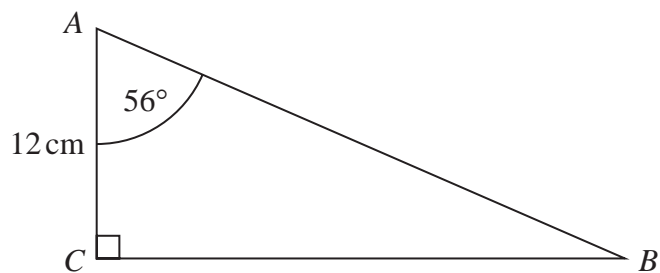

- (a) Work out the length of  $BC$ .  
Give your answer correct to 1 decimal place.

..... cm  
(2)

$PQR$  is a right-angled triangle.

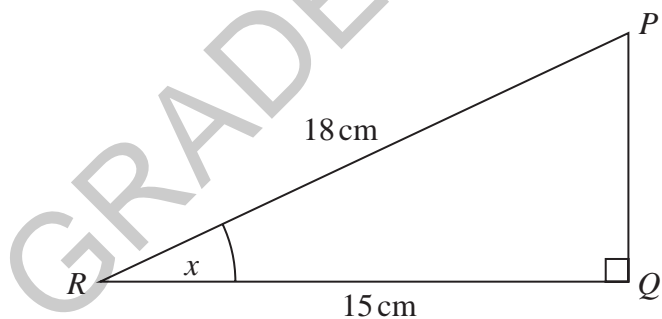

- (b) Work out the size of the angle marked  $x$ .  
Give your answer correct to 1 decimal place.

.....  
(2)

(Total for Question 6 is 4 marks)



- 7 Liquid **A** has a density of  $1.8 \text{ g/cm}^3$   
Liquid **B** has a density of  $1.2 \text{ g/cm}^3$

$80 \text{ cm}^3$  of liquid **A** is mixed with  $40 \text{ cm}^3$  of liquid **B** to make  $120 \text{ cm}^3$  of liquid **C**.

Work out the density of liquid **C**.

.....  $\text{g/cm}^3$

(Total for Question 7 is 3 marks)

GRADEUP.UK

DO NOT WRITE IN THIS AREA

DO NOT WRITE IN THIS AREA

DO NOT WRITE IN THIS AREA



- 8 The grouped frequency table gives information about the time, in minutes, taken by 50 people to solve a puzzle.

Time ( $t$ minutes)	Frequency
$0 < t \leq 10$	5
$10 < t \leq 20$	8
$20 < t \leq 30$	12
$30 < t \leq 40$	15
$40 < t \leq 50$	7
$50 < t \leq 60$	3

Brian was asked to draw a cumulative frequency table for this information.

This is the table that Brian drew.

Time ( $t$ minutes)	Cumulative frequency
$0 < t \leq 10$	5
$10 < t \leq 20$	13
$20 < t \leq 30$	25
$30 < t \leq 40$	40
$40 < t \leq 50$	47
$50 < t \leq 60$	50

Write down **one** thing that is wrong with this cumulative frequency table.

.....

.....

.....

(Total for Question 8 is 1 mark)



- 9 The box plot shows information about the length of time, in minutes, some people waited to see a doctor at a hospital on Monday.

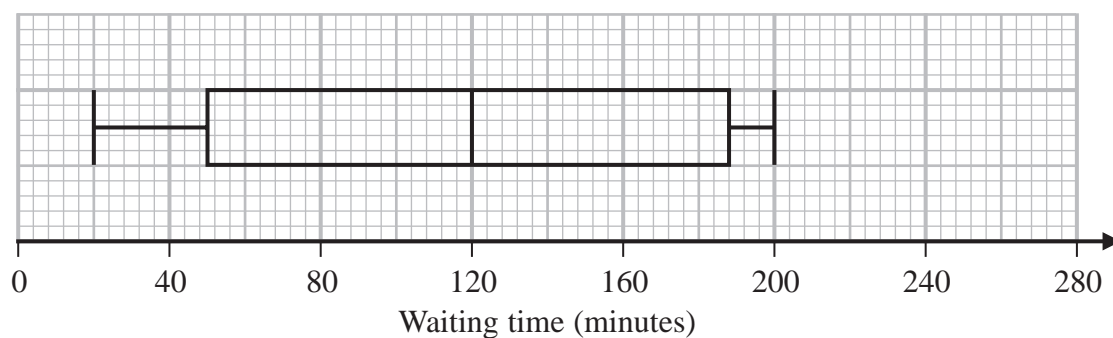

- (a) Work out the interquartile range of the information in the box plot.

..... minutes  
(2)

Becky says,

“50% of the people waited for at least 2 hours.”

- (b) Is Becky correct?  
Explain why.

.....  
(1)



The table gives information about the length of time, in minutes, some people waited to see a doctor at the same hospital on Tuesday.

	Waiting time (minutes)
Shortest time	20
Lower quartile	50
Median	100
Upper quartile	140
Longest time	210

Becky was asked to compare the distribution of the lengths of times people waited on Monday with the distribution of the lengths of times people waited on Tuesday.

She wrote,

“People had to wait longer on Tuesday than on Monday.”

(c) Give **one** reason why Becky may be wrong.

(1)

(Total for Question 9 is 4 marks)



P 6 4 6 3 2 A 0 1 1 2 4

- 10 Louise invests  $\pounds x$  in Better Investments for 3 years.  
Sadiq invests  $\pounds x$  in County Bank for 3 years.

<b>Better Investments</b>
Compound Interest
2.5% per annum

<b>County Bank</b>
Compound Interest
2% per annum for the first two years
3.5% per annum for each extra year

At the end of the 3 years, the value of Louise's investment is  $\pounds 344\,605$

Work out the value of Sadiq's investment at the end of the 3 years.

GRADEUP.UK

£.....

(Total for Question 10 is 4 marks)

DO NOT WRITE IN THIS AREA

DO NOT WRITE IN THIS AREA

DO NOT WRITE IN THIS AREA



DO NOT WRITE IN THIS AREA

DO NOT WRITE IN THIS AREA

DO NOT WRITE IN THIS AREA

11 Here is a sketch of the line L.

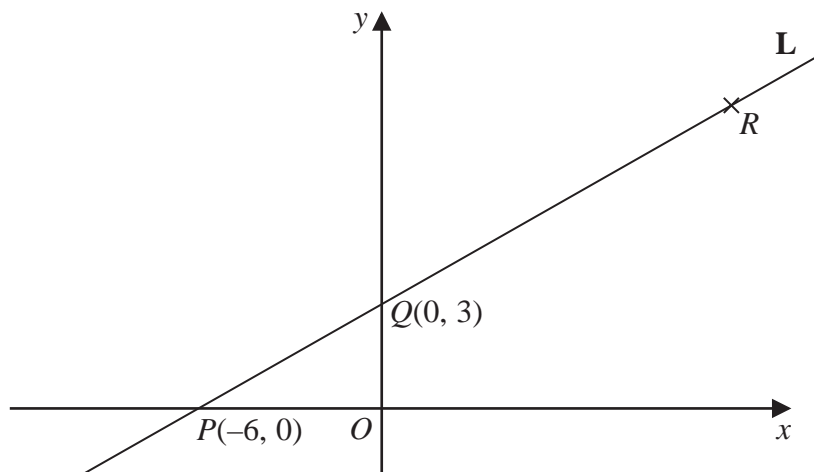

The points  $P(-6, 0)$  and  $Q(0, 3)$  are points on the line L.

The point R is such that PQR is a straight line and  $PQ:QR = 2:3$

(a) Find the coordinates of R.

(....., .....)  
(2)

(b) Find an equation of the line that is perpendicular to L and passes through Q.

.....  
(3)

(Total for Question 11 is 5 marks)



12 Expand and simplify  $(x - 2)(3x + 2)(2x + 3)$

.....  
(Total for Question 12 is 3 marks)

13 In a school there are 16 teachers and 220 students.  
Of these students 120 are girls and 100 are boys.

One teacher, one girl and one boy are going to be chosen to represent the school.

Work out the number of different ways there are to choose one teacher, one girl and one boy.

.....  
(Total for Question 13 is 2 marks)

DO NOT WRITE IN THIS AREA

DO NOT WRITE IN THIS AREA

DO NOT WRITE IN THIS AREA



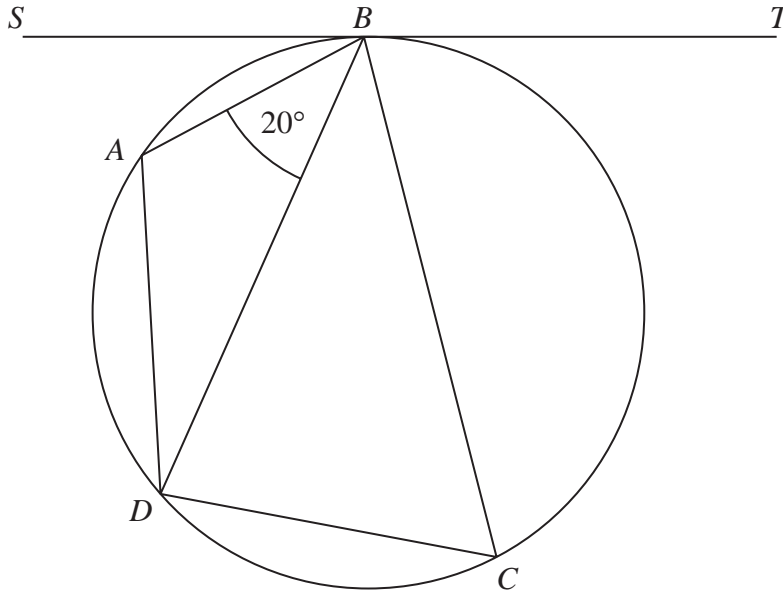

$A$ ,  $B$ ,  $C$  and  $D$  are four points on a circle.  
 $SBT$  is a tangent to the circle.  
 Angle  $ABD = 20^\circ$

the size of angle  $BAD$  : the size of angle  $BCD = 3 : 1$

Find the size of angle  $SBA$ .  
 Give a reason for each stage of your working.

(Total for Question 14 is 4 marks)

o



15 Here is triangle  $ABC$ .

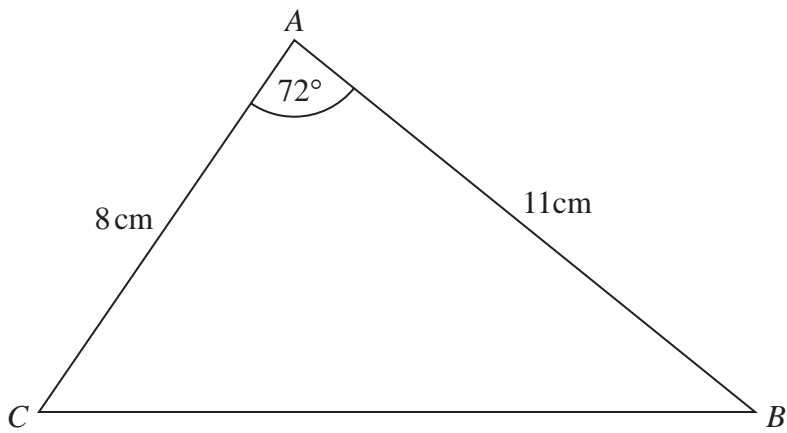

- (a) Find the length of  $BC$ .  
Give your answer correct to 3 significant figures.

..... cm  
(3)

- (b) Find the area of triangle  $ABC$ .  
Give your answer correct to 3 significant figures.

.....  $\text{cm}^2$   
(2)

(Total for Question 15 is 5 marks)

DO NOT WRITE IN THIS AREA

DO NOT WRITE IN THIS AREA

DO NOT WRITE IN THIS AREA



DO NOT WRITE IN THIS AREA

DO NOT WRITE IN THIS AREA

DO NOT WRITE IN THIS AREA

16 (a) Use the iteration formula  $x_{n+1} = \sqrt[3]{10 - 2x_n}$  to find the values of  $x_1$ ,  $x_2$  and  $x_3$   
Start with  $x_0 = 2$

GRADEUP.UK

$x_1 =$  .....

$x_2 =$  .....

$x_3 =$  .....

(3)

The values of  $x_1$ ,  $x_2$  and  $x_3$  found in part (a) are estimates of the solution of an equation of the form  $x^3 + ax + b = 0$  where  $a$  and  $b$  are integers.

(b) Find the value of  $a$  and the value of  $b$ .

$a =$  .....

$b =$  .....

(1)

(Total for Question 16 is 4 marks)



P 6 4 6 3 2 A 0 1 7 2 4

17 Some people took part in the first round of a competition.

The histogram gives information about the scores of these people in the first round.

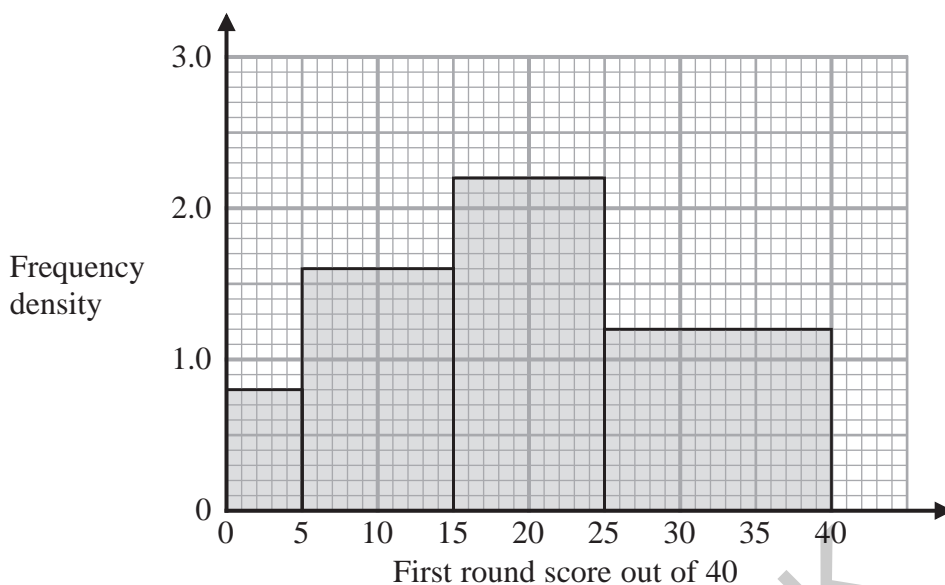

20% of the people got a score high enough for them to qualify for the second round.

Work out an estimate for the score needed to qualify for the second round.

You must show all your working.

(Total for Question 17 is 4 marks)



DO NOT WRITE IN THIS AREA

DO NOT WRITE IN THIS AREA

DO NOT WRITE IN THIS AREA

18 Here is a graph of  $y = \sin x^\circ$  for  $0 \leq x \leq 360$

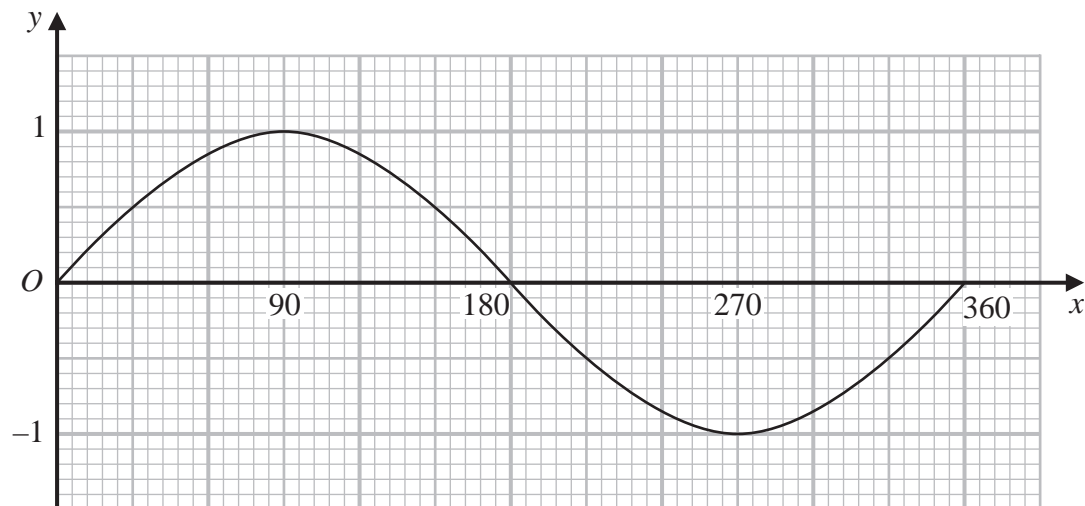

(a) Using this graph, find estimates of all **four** solutions of

$$\sin x^\circ = 0.6 \text{ for } 0 \leq x \leq 720$$

..... (2)

The graph of  $y = \sin x^\circ$  is reflected in the  $x$ -axis.

(b) Write down an equation of the reflected graph.

..... (1)

Here is a graph of  $y = f(x)$

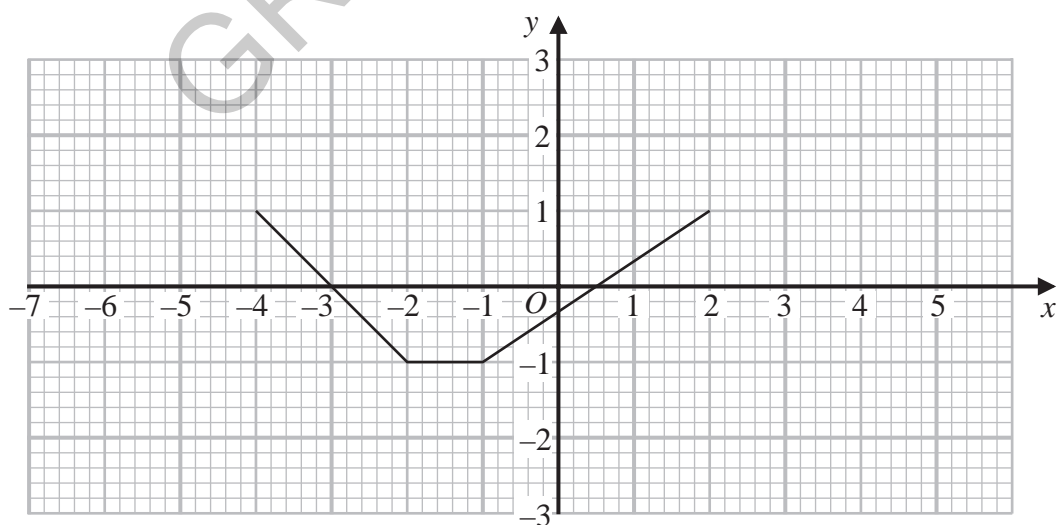

(c) On the grid, draw the graph of  $y = f(x - 2)$

(1)

(Total for Question 18 is 4 marks)



19 **A**, **B** and **C** are three spheres.

The volume of sphere **A** is  $125 \text{ cm}^3$

The volume of sphere **B** is  $27 \text{ cm}^3$

The ratio of the radius of sphere **B** to the radius of sphere **C** is 1 : 2

Work out the ratio of the surface area of sphere **A** to the surface area of sphere **C**.

GRADEUP.UK

.....  
(Total for Question 19 is 3 marks)

DO NOT WRITE IN THIS AREA

DO NOT WRITE IN THIS AREA

DO NOT WRITE IN THIS AREA



20 In a village,

if it rains on one day, the probability that it will rain on the next day is 0.8

if it does **not** rain on one day, the probability that it will rain on the next day is 0.6

A weather forecaster says,

“There is a 70% chance that it will rain in the village on Monday.”

Work out an estimate for the probability that it will rain in the village on Wednesday.

You must show all your working.

GRADEUP.UK

.....  
(Total for Question 20 is 4 marks)



21 The time period,  $T$  seconds, of a simple pendulum of length  $l$  cm is given by the formula

$$T = 2\pi \sqrt{\frac{l}{g}}$$

Katie uses a simple pendulum in an experiment to find an estimate for the value of  $g$ .

Here are her results.

$l = 52.0$  correct to 3 significant figures.

$T = 1.45$  correct to 3 significant figures.

Work out the upper bound and the lower bound for the value of  $g$ .

Use  $\pi = 3.142$

You must show all your working.

GRADEUP.UK

upper bound = .....

lower bound = .....

(Total for Question 21 is 4 marks)

TOTAL FOR PAPER IS 80 MARKS



DO NOT WRITE IN THIS AREA

DO NOT WRITE IN THIS AREA

DO NOT WRITE IN THIS AREA

GRADEUP.UK

**BLANK PAGE**



P 6 4 6 3 2 A 0 2 3 2 4

DO NOT WRITE IN THIS AREA

DO NOT WRITE IN THIS AREA

DO NOT WRITE IN THIS AREA

GRADEUP.UK

BLANK PAGE

