

OCR

Oxford Cambridge and RSA

Friday 17 May 2024 – Morning

GCSE (9–1) Chemistry A (Gateway Science)

J248/01 (Foundation Tier)

Time allowed: 1 hour 45 minutes

You must have:

- a ruler (cm/mm)
- the Data Sheet for GCSE (9–1) Chemistry A (inside this document)

You can use:

- a scientific or graphical calculator
- an HB pencil



Please write clearly in black ink. **Do not write in the barcodes.**

Centre number

--	--	--	--	--

Candidate number

--	--	--	--

First name(s)

Last name

INSTRUCTIONS

- Use black ink. You can use an HB pencil, but only for graphs and diagrams.
- Write your answer to each question in the space provided. If you need extra space use the lined page at the end of this booklet. The question numbers must be clearly shown.
- Answer **all** the questions.
- Where appropriate, your answer should be supported with working. Marks might be given for using a correct method, even if your answer is wrong.

INFORMATION

- The total mark for this paper is **90**.
- The marks for each question are shown in brackets [].
- Quality of extended response will be assessed in questions marked with an asterisk (*).
- This document has **28** pages.

ADVICE

- Read each question carefully before you start your answer.

Section A

You should spend a **maximum** of **30 minutes** on this section.

Write your answer to each question in the box provided.

1 Which part of an atom is **negatively** charged?

- A Electron
- B Neutron
- C Nucleus
- D Proton

Your answer

[1]

2 Which of these changes is a **chemical** change?

- A Ice melting
- B Shaping hot metal with a hammer
- C Water condensing
- D Wood burning

Your answer

[1]

3 Which group of elements on the Periodic Table has a full outer shell of electrons?

- A 0
- B 1
- C 2
- D 7

Your answer

[1]

4 Sodium chloride, NaCl , is an ionic compound.

How are the ions held together in sodium chloride?

- A Covalent bonds
- B Delocalised electrons
- C Electrostatic forces
- D Intermolecular forces

Your answer

[1]

5 Which equipment is used for **filtration**?

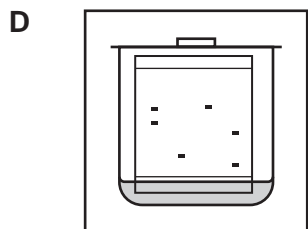
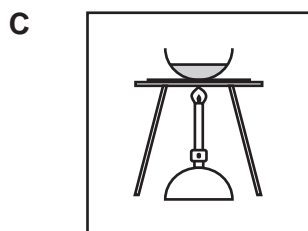
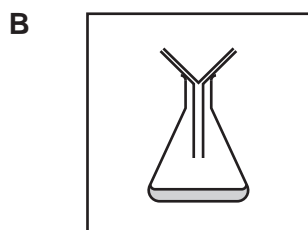
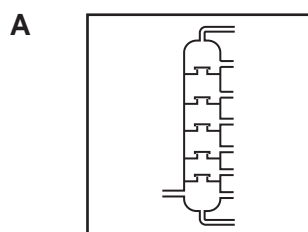

Your answer

[1]

6 Which scientist suggested the idea that electrons exist in electron shells?

- A Bohr
- B Dalton
- C Rutherford
- D Thomson

Your answer

[1]

7 Which row describes a **formulation**?

	Description	Amount of chemicals
A	compound	exact
B	mixture	exact
C	compound	random
D	mixture	random

Your answer

[1]

8 The table shows information about some atoms and ions.

Which two are **isotopes**?

Atom or ion	Number of protons	Number of neutrons	Number of electrons
1	17	18	17
2	17	18	18
3	17	20	17
4	18	20	18

- A 1 and 2
- B 1 and 3
- C 2 and 4
- D 3 and 4

Your answer

[1]

9 Which dot and cross diagram shows the structure of a fluorine molecule, F_2 ?

A

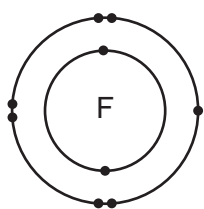

B

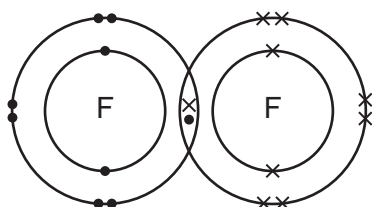

C

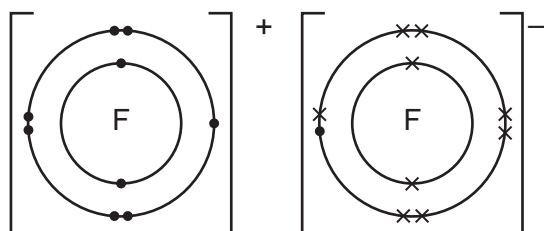

D

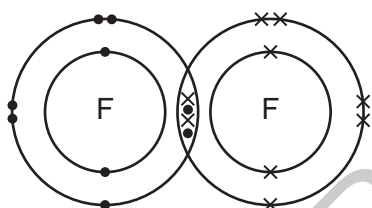

Your answer

[1]

10 What is the balanced symbol equation for the reaction of methane with oxygen?

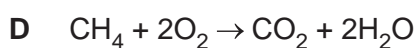
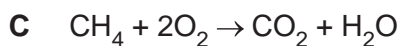
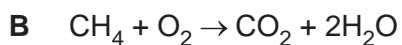
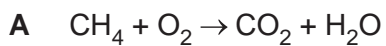

Your answer

[1]

- 11 11.0g of aluminium reacts with 43.4g of chlorine to make 54.4g of aluminium chloride.

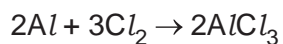

How much **aluminium** is required to make 217.6g of aluminium chloride?

- A 22.0g
- B 44.0g
- C 86.8g
- D 173.6g

Your answer

[1]

- 12 The table shows the start and end temperatures of four reactions.

Which reaction is endothermic?

	Temperature at start (°C)	Temperature at end (°C)
A	19.0	19.0
B	19.0	15.2
C	20.0	23.2
D	20.0	21.0

Your answer

[1]

- 13 Which reaction profile shows an **exothermic** reaction with the arrow marking the activation energy?

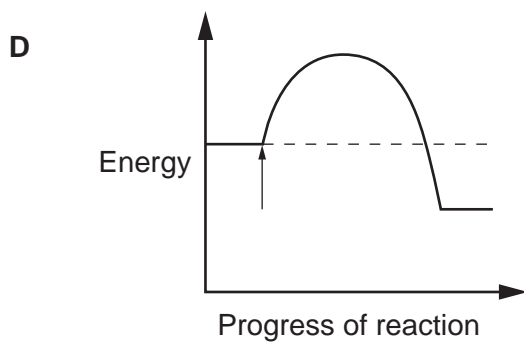
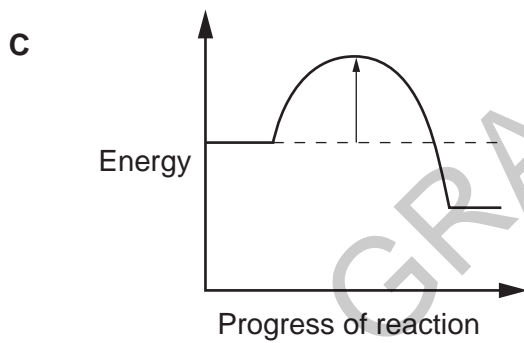
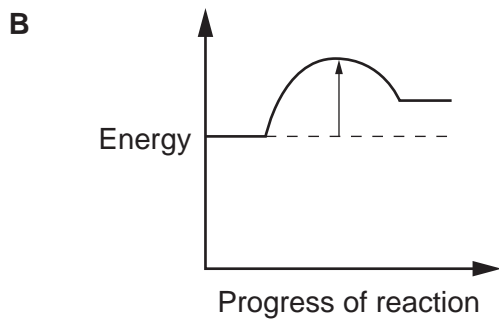
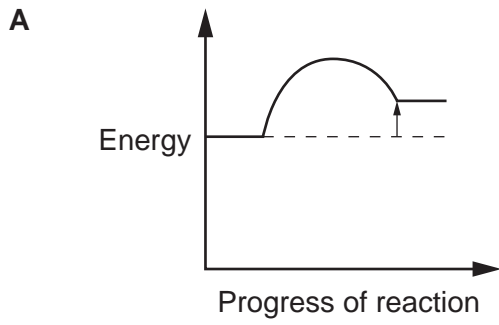

Your answer

[1]

- 14 The electrolysis of molten copper chloride makes copper metal and chlorine gas.

Which row describes what happens to the inert electrodes during the electrolysis of molten copper chloride?

- A Mass of both electrodes decreases
 B Mass of both electrodes increases
 C Mass of one electrode increases, mass of one electrode decreases
 D Mass of one electrode increases, mass of one electrode stays the same

Your answer

[1]

- 15 The diagram shows the electrolysis of molten sodium chloride.

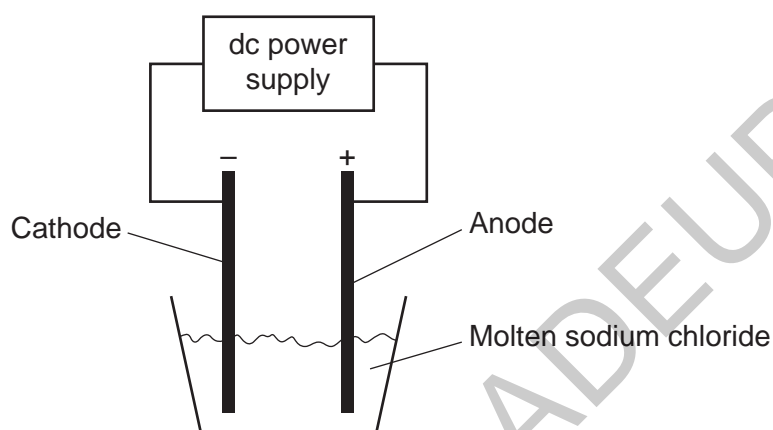

Which products are made in the electrolysis of molten sodium chloride?

	Product at anode	Product at cathode
A	chlorine	hydrogen
B	chlorine	sodium
C	hydrogen	chlorine
D	sodium	chlorine

Your answer

[1]

GRADEUP.UK

PLEASE DO NOT WRITE ON THIS PAGE

10
Section B

16 Water boils at 100 °C and freezes at 0 °C.

(a) Draw lines to connect each **temperature** with the **particle model** of water.

Temperature

Particle Model

-5 °C

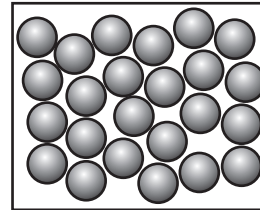

25 °C

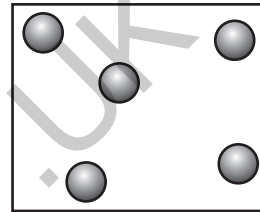

110 °C

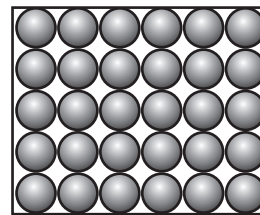

[2]

(b) Water, H₂O, contains hydrogen and oxygen atoms.

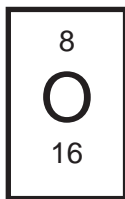

(i) How many protons does an oxygen atom have?

..... [1]

(ii) How many neutrons does a hydrogen atom have?

..... [1]

(iii) What is the relative charge of a proton?

..... [1]

(c) A water molecule can be represented with different models.

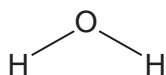

Model 1

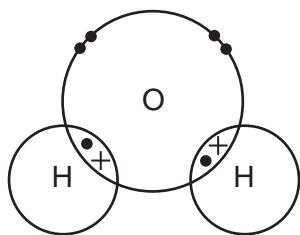

Model 2

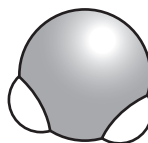

Model 3

Which model would you use to show the **volume** of a water molecule?

Explain your answer.

Model

Reason

.....

[2]

(d) Water is formed from the reaction of hydrogen, H_2 , and oxygen, O_2 .

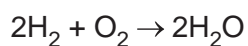

Hydrogen is **oxidised** in the reaction.

Explain how you can tell from the equation.

.....

..... [1]

17 A student investigates a neutralisation reaction between an acid and an alkali.

(a) Complete the sentences about how the student investigates the neutralisation reaction.

Use words from the list.

Clamp stand	Conical flask	Measuring cylinder
pH meter	Pipette	Thermometer

The student uses a to measure the volume of acid.

They use a to test the pH of the acid.

[2]

(b) The student adds universal indicator to the acid.

The student predicts the colour change they think will happen when they add the alkali to the acid.

Colour of indicator before alkali is added	Red
Colour of indicator when solution is neutral	Green
Colour of indicator when too much alkali has been added	Yellow

Do you agree with the student?

Tick (✓) **one** box.

The student is completely correct.

The student is partly correct.

The student is completely incorrect.

Explain your answer.

.....

.....

.....

[3]

(c) The table shows the volume of alkali the student adds in each experiment.

Experiment	Volume of alkali added (cm ³)
1	24.2
2	24.4
3	23.9
4	24.0

Calculate the mean volume of alkali added.

Give your answer to **3** significant figures.

Mean volume of alkali added = cm³ [3]

(d) Complete the **word** equation for a neutralisation reaction.

acid + alkali → + [2]

(e) Which **two** ions react together in neutralisation reactions to form H₂O?

Put a **ring** around **two** ions.

Cl⁺ Cl⁻ H⁺ H⁻ OH⁺ OH⁻ [1]

18

(a) The diagram shows how a town is recycling plastic waste.

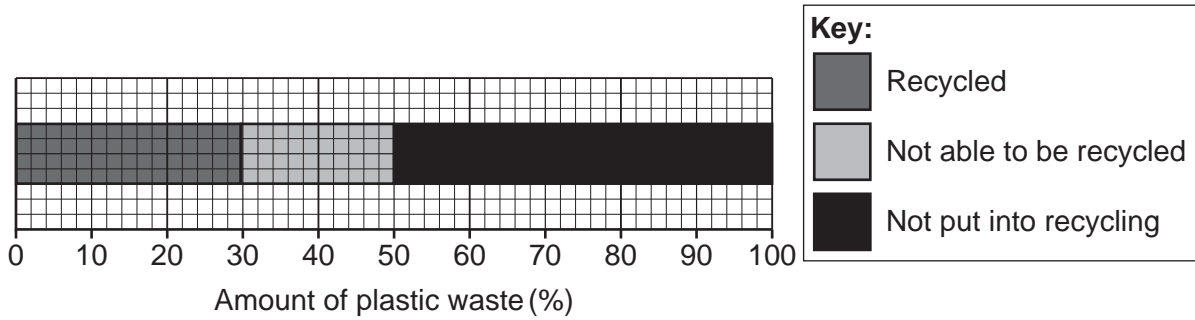

The town generates a total of 45 000 kg of plastic waste in a year.

Calculate the mass of plastic waste that is **not able to be recycled** in the town.

Mass of plastic waste not able to be recycled = kg [3]

(b) Plastics are polymers. Polymers have covalent bonds between the atoms.

(i) Explain what a **covalent bond** is in terms of electrons.

.....
 [1]

(ii) Describe **two** differences between a polymer used to make a plastic bag and a polymer used to make a plastic bottle.

1

 2
 [2]

- (c) A scientist wants to choose a polymer that is suitable for making a plastic ruler.

The scientist says that a polymer that stretches will **not** be suitable for making a ruler.

The diagram shows the ruler before and after stretching.

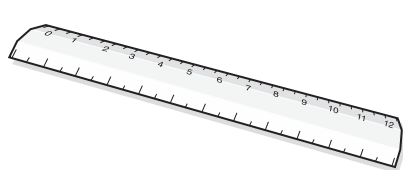

Before stretching



After stretching

Explain why the scientist is **correct**.

.....

.....

.....

[2]

- (d) The properties of four different polymer samples are shown in the table.

Polymer	Melting point of sample (°C)	Distance the sample stretches before breaking (cm)
PET	260	0.0
PVC	110	12.5
PS	240	0.1
PE	125	10.4

- (i) Describe the relationship between the melting point of the sample and the distance the sample stretches before breaking.

.....

..... [1]

- (ii) The molecular formula of the monomer used to make PET is $C_{10}H_{10}O_5$.

State the **empirical** formula of the monomer used to make PET.

..... [1]

19

- (a) A student investigates the reaction between sodium carbonate, Na_2CO_3 , and sulfuric acid, H_2SO_4 .

Sodium sulfate, water and carbon dioxide are made.

- (i) Complete the **balanced symbol** equation for the reaction.

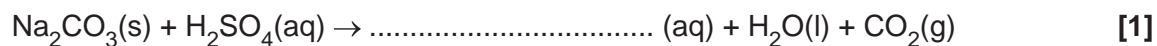

- (ii) Sulfuric acid has the state symbol (aq).

What does (aq) mean?

..... [1]

- (iii) One of the products is a gas. The student wants to collect the gas formed.

Complete the diagram to show how they can collect and measure the volume of gas.

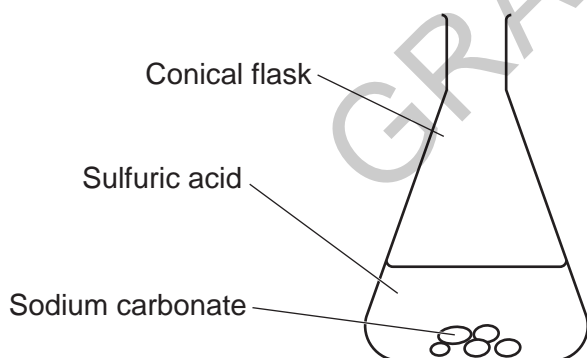

[2]

(b) The table shows the student's results.

Time (minutes)	Volume of gas collected (cm ³)
0	0.0
2	2.0
4	3.5
6	4.4
8	4.9
10	5.1
12	5.1
14	5.1

(i) Plot the results from the table on the graph.

Six points have already been plotted.

[1]

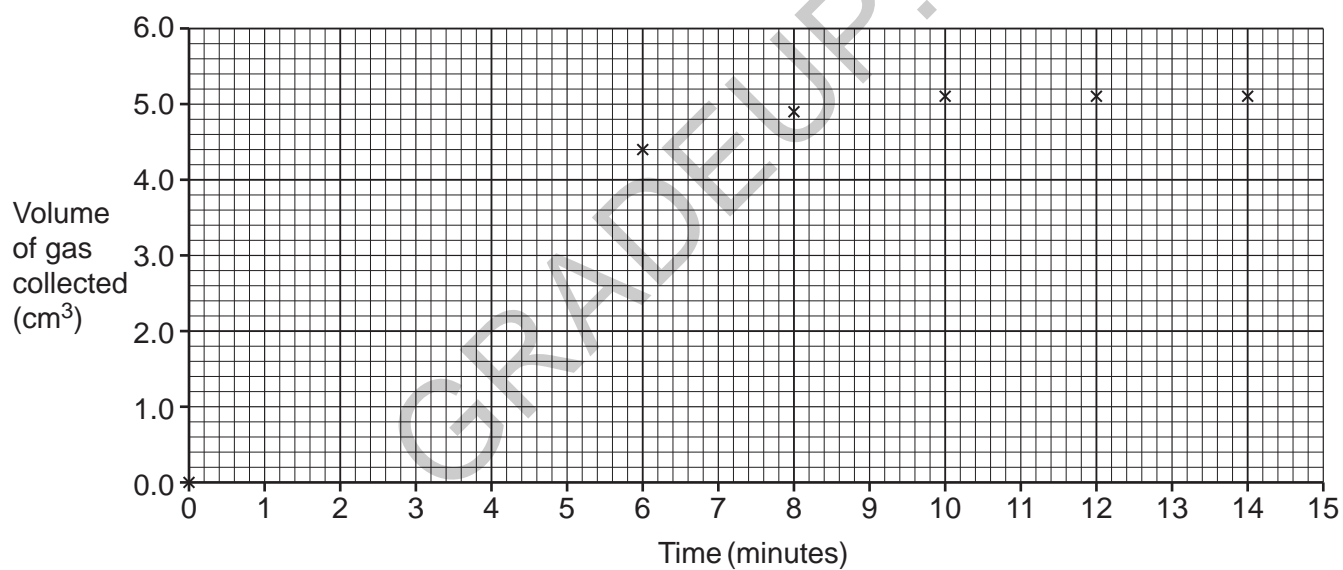

(ii) Draw a curve of best fit.

[1]

(iii) Use the graph to estimate the volume of gas that has been collected at 7.5 minutes.

Volume of gas collected = cm³ [1]

(iv) The student collects 5.1 cm³ of gas.

The student wants to collect more gas.

How does the student change the experiment so that more gas is collected?

Tick (✓) **one** box.

Use a larger conical flask

Use less sodium carbonate

Use less sulfuric acid

Use more sulfuric acid

[1]

GRADEUP.UK

19
BLANK PAGE

PLEASE DO NOT WRITE ON THIS PAGE

GRADEUP.UK

- (b) In his Periodic Table, Mendeleev noticed that when elements were arranged in order of atomic mass, some elements seemed to be in the wrong place.

Complete the sentences about Mendeleev's Periodic Table.

Use words from the list.

had the wrong mass	left gaps for	neutrons	properties
reweighed	were undiscovered		

Mendeleev grouped the elements according to their

He predicted that some elements

He these elements.

[3]

- (c) Lithium is in Group 1 of the Periodic Table and helium is in Group 0.

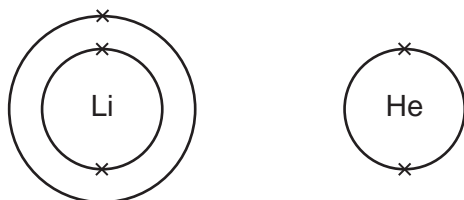

Explain why Group 1 elements are reactive, but Group 0 elements are unreactive.

.....

.....

.....

..... [2]

21 A carbon atom is 1.7×10^{-10} m wide.

A diamond is 4.0×10^{-3} m wide.

(a) How many **orders of magnitude** larger is the diamond than the carbon atom?

Tick (✓) **one** box.

Two

Four

Seven

[1]

(b) Calculate the number of carbon atoms that fit in the width of the diamond.

Give your answer in **standard form** to **1** decimal place.

Number of carbon atoms = [3]

(c) The diagram shows the structure of diamond.

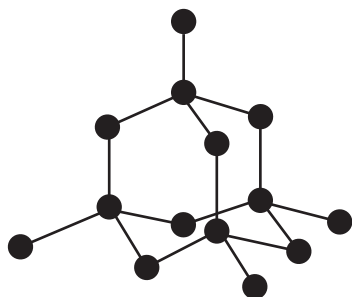

Explain why diamond **cannot** conduct electricity.

.....

.....

.....

..... [2]

(d) Some properties of forms of carbon are shown in the table.

Form of carbon	Conducts electricity?	Conducts heat?	Melting point
X	yes	yes	very high
Y	no	yes	high
Z	no	no	very high

(i) Which form of carbon should you choose to use as an electrode in an electrolysis experiment with a molten electrolyte?

Explain your answer.

Form of carbon

Reason

[2]

(ii) All of the melting points in the table are high.

Why is it important that electrodes used in a **molten** electrolyte have a high melting point?

Tick (✓) **one** box.

Electrodes need to remain liquid, and not freeze at low temperatures

Electrodes need to remain liquid, and not melt at high temperatures

Electrodes need to remain solid, and not freeze at low temperatures

Electrodes need to remain solid, and not melt at high temperatures

[1]

22

- (a) A scientist investigates dissolving four different tablets in water.

Each tablet has a different surface area.

They add each tablet to 20 cm^3 of water and time how long it takes for the tablet to dissolve.

The table shows their results.

Tablet	Surface area of tablet (cm^2)	Volume of tablet (cm^3)	Surface area to volume ratio	Time taken to dissolve (seconds)
A	2.8	0.3	9.33 : 1	43
B	2.5	0.2	12.5 : 1	27
C	1.5	0.2		62
D	3.0	0.2	15.0 : 1	

- (i) Calculate the surface area to volume ratio of tablet C.

Surface area to volume ratio = [2]

- (ii) Complete the sentence to describe the relationship between the surface area to volume ratio and the time taken to dissolve.

As the surface area to volume ratio,

the tablet will take time to dissolve.

[1]

- (iii) The scientist thinks that tablet D will dissolve **slowest** in 20 cm^3 of water.

Explain why the scientist is **incorrect**.

.....

.....

.....

[2]

(b) The scientist performs thin layer chromatography on solutions of each of the tablets.

(i) The spots on the chromatogram are **colourless**.

State what the scientist could use to see the spots.

..... [1]

(ii) After the scientist uses a method to see the spots, the chromatogram for Tablet A is shown.

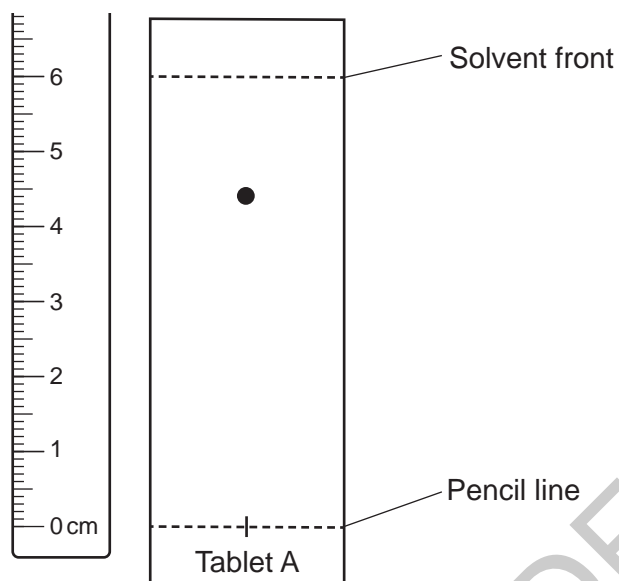

Calculate the R_f value for the spot seen from tablet A.

R_f value = [3]

23 A student wants to separate a mixture of compounds.

Different separation methods are used depending on the mixture.

(a) Draw lines to connect each **separation method** to the correct **mixture**.

Separation method	Mixture
Crystallisation	Insoluble solid and liquid
Filtration	Solution containing a soluble solid dissolved in a liquid
Fractional distillation	Three liquids with different boiling points

[2]

(b) The student decides to use simple distillation to separate a mixture.

They set up the apparatus shown in the diagram.

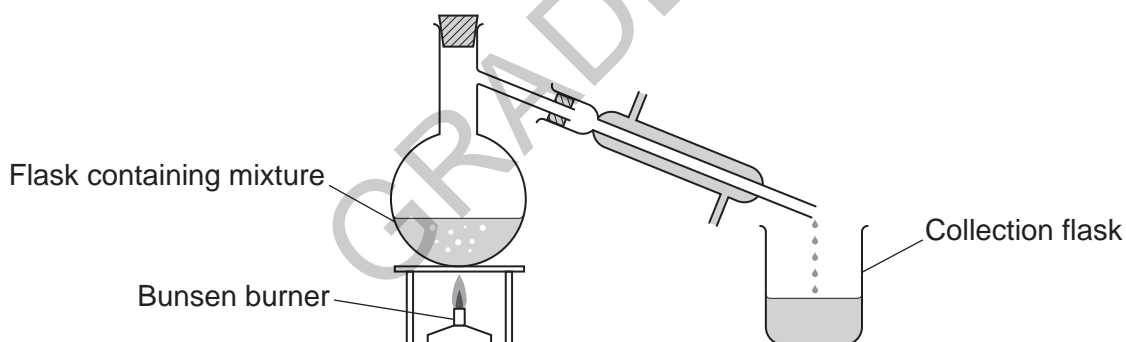

(i) A liquid in the mixture is **flammable**.

Suggest a change the student could make to the apparatus to make the distillation safer.

.....
 [1]

- (ii) The student wants to record the boiling point of the pure liquid that is collected in the collection flask.

Suggest an improvement the student could make to the apparatus so that they can record the boiling point.

.....
..... [1]

- (c) The pure liquid collected has the molecular formula $(C_2H_5)_2O$ and a boiling point of $35^\circ C$.

Which statements about the pure liquid are **correct**?

Tick (✓) **two** boxes.

The empirical formula is CH_2 .

The melting point is lower than $35^\circ C$.

The pure liquid contains two compounds.

The pure liquid is an element.

The pure liquid will be a gas at above $35^\circ C$.

[2]

- (d) Calculate the relative formula mass of a $(C_2H_5)_2O$ molecule.

Relative atomic mass (A_r): C = 12.0 H = 1.0 O = 16.0

Relative formula mass = [3]

END OF QUESTION PAPER

EXTRA ANSWER SPACE

If you need extra space use this lined page. You must write the question numbers clearly in the margin.

Lined area for writing answers, featuring a vertical margin line on the left and horizontal dotted lines for writing.

GRADEUP.UK

OCR

Oxford Cambridge and RSA

Copyright Information

OCR is committed to seeking permission to reproduce all third-party content that it uses in its assessment materials. OCR has attempted to identify and contact all copyright holders whose work is used in this paper. To avoid the issue of disclosure of answer-related information to candidates, all copyright acknowledgements are reproduced in the OCR Copyright Acknowledgements Booklet. This is produced for each series of examinations and is freely available to download from our public website (www.ocr.org.uk) after the live examination series.

If OCR has unwittingly failed to correctly acknowledge or clear any third-party content in this assessment material, OCR will be happy to correct its mistake at the earliest possible opportunity.

For queries or further information please contact The OCR Copyright Team, The Triangle Building, Shaftesbury Road, Cambridge CB2 8EA.

OCR is part of Cambridge University Press & Assessment, which is itself a department of the University of Cambridge.