

Please check the examination details below before entering your candidate information

Candidate surname

Other names

Centre Number

Candidate Number

## Pearson Edexcel Level 1/Level 2 GCSE (9–1)

### Monday 10 June 2024

Morning (Time: 1 hour 30 minutes)

Paper  
reference

# 1MA1/3H

## Mathematics

### PAPER 3 (Calculator)

### Higher Tier



**You must have:** Ruler graduated in centimetres and millimetres, protractor, pair of compasses, pen, HB or B pencil, eraser, calculator, Formulae Sheet (enclosed). Tracing paper may be used.

Total Marks

### Instructions

- Use **black** ink or ball-point pen.
- If pencil is used for diagrams/sketches/graphs it must be dark (HB or B).
- **Fill in the boxes** at the top of this page with your name, centre number and candidate number.
- Answer **all** questions.
- Answer the questions in the spaces provided  
– *there may be more space than you need.*
- You must **show all your working**.
- Diagrams are **NOT** accurately drawn, unless otherwise indicated.
- **Calculators may be used.**
- If your calculator does not have a  $\pi$  button, take the value of  $\pi$  to be 3.142 unless the question instructs otherwise.

### Information

- The total mark for this paper is 80
- The marks for **each** question are shown in brackets  
– *use this as a guide as to how much time to spend on each question.*

### Advice

- Read each question carefully before you start to answer it.
- Try to answer every question.
- Check your answers if you have time at the end.

Turn over ►

P76927A

©2024 Pearson Education Ltd.  
F:1/1/1/



  
Pearson

**Answer ALL questions.**

**Write your answers in the spaces provided.**

**You must write down all the stages in your working.**

- 1 Find the highest common factor (HCF) of 63 and 105

.....  
(Total for Question 1 is 2 marks)

GRADEUP.UK

DO NOT WRITE IN THIS AREA

DO NOT WRITE IN THIS AREA

DO NOT WRITE IN THIS AREA



DO NOT WRITE IN THIS AREA

DO NOT WRITE IN THIS AREA

DO NOT WRITE IN THIS AREA

2 (a) (i) Write  $5.3 \times 10^4$  as an ordinary number.

.....  
(1)

(ii) Write  $7.4 \times 10^{-5}$  as an ordinary number.

.....  
(1)

(b) Calculate the value of  $9.7 \times 10^6 + 2.45 \times 10^7$   
Give your answer in standard form.

.....  
(2)

**(Total for Question 2 is 4 marks)**



P 7 6 9 2 7 A 0 3 2 4

3 The diagram shows a solid triangular prism.

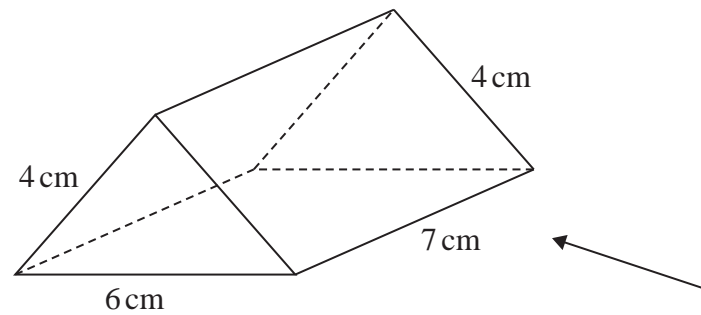

Rana is trying to draw the side elevation of the solid prism from the direction of the arrow.

Here is her answer on a centimetre grid.

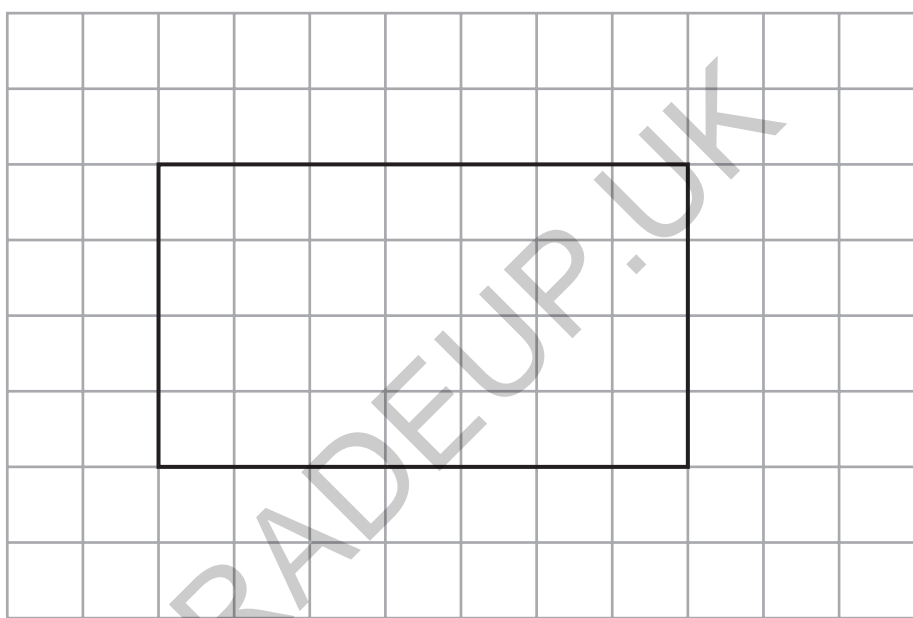

(a) Explain why Rana's side elevation is not correct.

.....

.....

.....

(1)



DO NOT WRITE IN THIS AREA

DO NOT WRITE IN THIS AREA

DO NOT WRITE IN THIS AREA

(b) On the centimetre grid below, draw a plan of the solid prism.

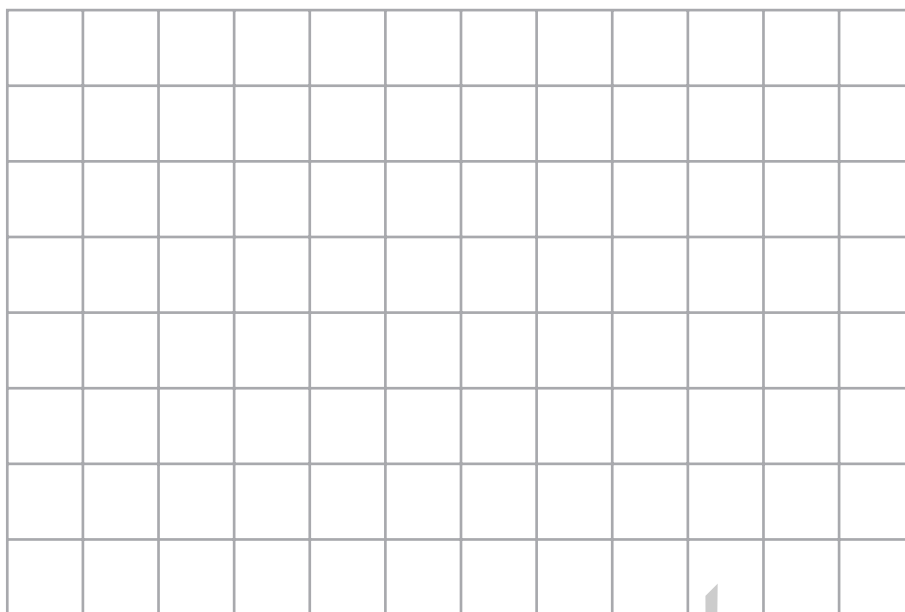

(2)

(Total for Question 3 is 3 marks)

- 4 A company has 25 000 workers.  
The number of workers increases at a rate of 6% per year for 3 years.  
Calculate the total number of workers at the end of the 3 years.

(Total for Question 4 is 4 marks)



5 Habib has two identical tins.

He puts 600 grams of flour into one of the tins.

The flour fills the tin completely.

The density of the flour is  $0.6 \text{ g/cm}^3$

Habib puts 600 grams of salt into the other tin.

The salt does **not** fill the tin completely.

The volume of the space in the tin that is **not** filled with salt is  $700 \text{ cm}^3$

Work out the density of the salt.

You must show all your working.

.....  $\text{g/cm}^3$

(Total for Question 5 is 4 marks)

GRADEUP.UK



DO NOT WRITE IN THIS AREA

DO NOT WRITE IN THIS AREA

DO NOT WRITE IN THIS AREA

6 Tim has two biased coins, coin **A** and coin **B**.  
He is going to throw both coins.

The probability that coin **A** will land on heads is 0.6  
The probability that coin **B** will land on heads is 0.55

(a) Complete the probability tree diagram.

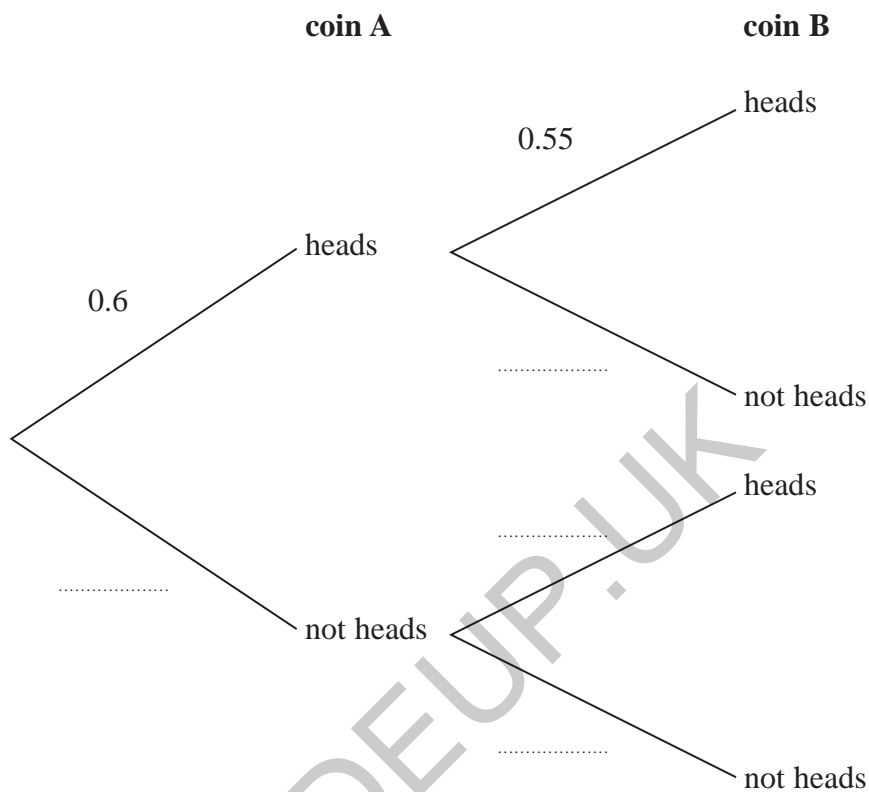

(2)

Tim throws coin **A** once and he throws coin **B** once.

(b) Work out the probability that both coins land on heads.

(2)

(Total for Question 6 is 4 marks)



7 A paddling pool is in the shape of a cylinder.

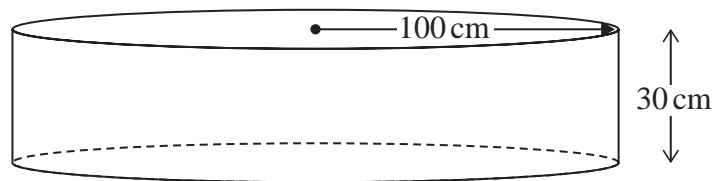

The pool has radius 100 cm.  
The pool has depth 30 cm.

The pool is empty.  
It is then filled with water at a rate of  $250 \text{ cm}^3$  per second.

Work out the number of minutes it takes to fill the pool completely.  
Give your answer correct to the nearest minute.  
You must show all your working.

GRADEUP.UK

..... minutes

(Total for Question 7 is 4 marks)



DO NOT WRITE IN THIS AREA

DO NOT WRITE IN THIS AREA

DO NOT WRITE IN THIS AREA

8  $\mathbf{a} = \begin{pmatrix} 3 \\ 2 \end{pmatrix}$      $\mathbf{b} = \begin{pmatrix} -1 \\ 4 \end{pmatrix}$

On the grid below, draw and label the vector  $2\mathbf{a} + \mathbf{b}$

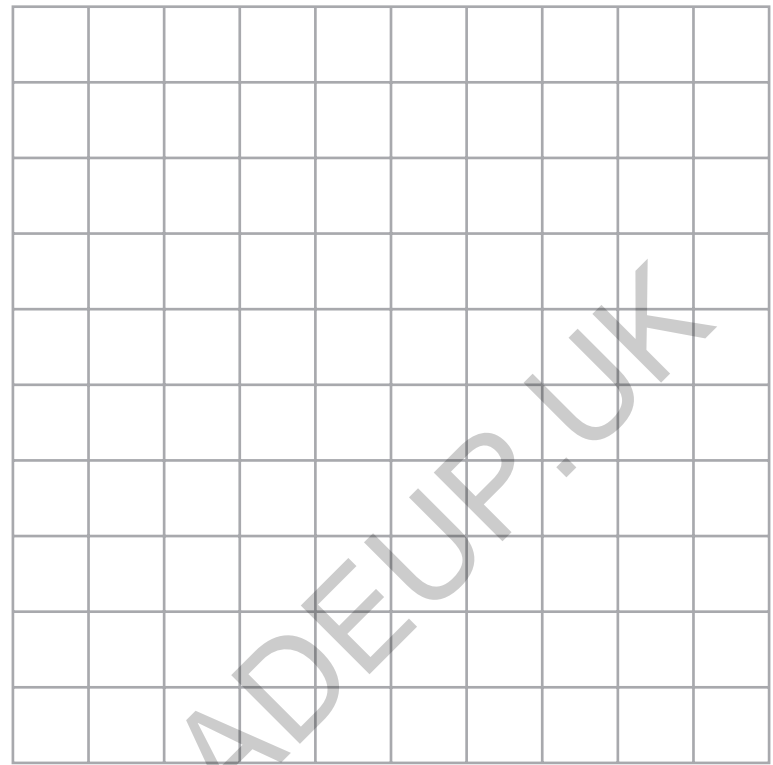

(Total for Question 8 is 3 marks)



9 The diagram shows a cube and a square-based pyramid.

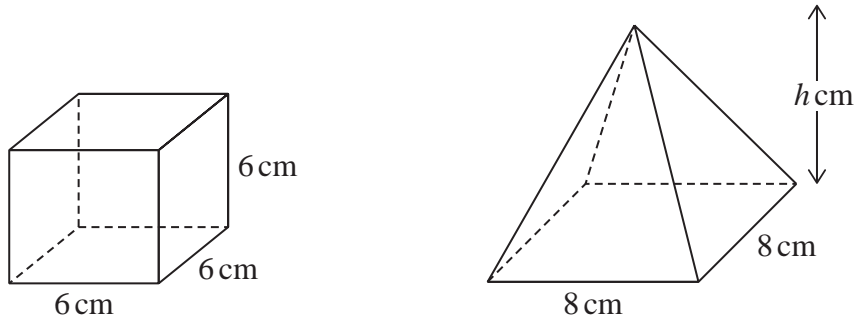

The volume of the cube is equal to the volume of the pyramid.

Work out the perpendicular height,  $h$  cm, of the pyramid.

GRADEUP.UK

..... cm

(Total for Question 9 is 3 marks)

DO NOT WRITE IN THIS AREA

DO NOT WRITE IN THIS AREA

DO NOT WRITE IN THIS AREA



DO NOT WRITE IN THIS AREA

DO NOT WRITE IN THIS AREA

DO NOT WRITE IN THIS AREA

10 There are only red counters and yellow counters in bag **A**.

$$\text{number of red counters} : \text{number of yellow counters} = 3 : 5$$

There are only green counters and blue counters in bag **B**.

The number of counters in bag **B** is half the number of counters in bag **A**.

Given that there are  $x$  red counters in bag **A**,

use algebra to show that the total number of counters in bag **A** and bag **B** is  $4x$

GRADEUP.UK

(Total for Question 10 is 3 marks)



11 Mina records the speeds, in mph, of some cars on a road on Friday. She uses her results to work out the information in this table.

	Speed (mph)
Lowest speed	25
Lower quartile	35
Median	40
Interquartile range	12
Range	37

(a) On the grid, draw a box plot to show the information in the table.

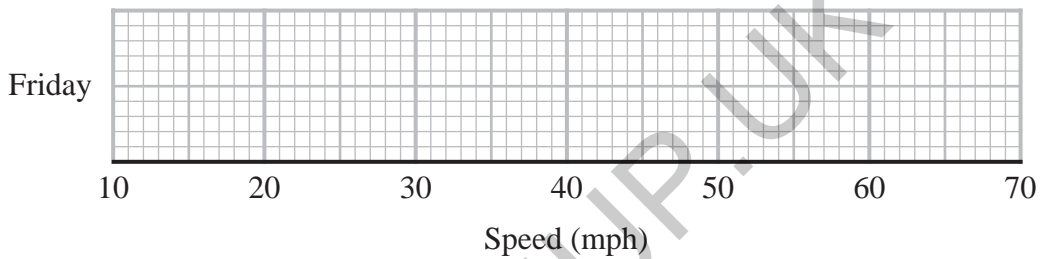

(3)

Mina also records the speeds of some cars on the same road on Sunday. She uses her results to draw this box plot.

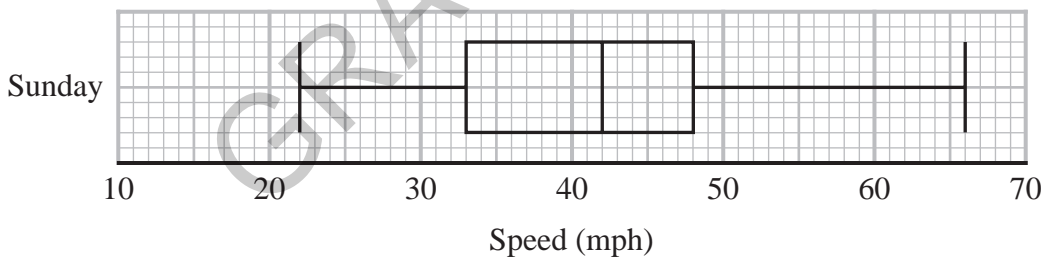

(b) Compare the distribution of the speeds on Friday with the distribution of the speeds on Sunday.

.....

.....

.....

.....

(2)

(Total for Question 11 is 5 marks)



12 The diagram shows triangle **T** drawn on a grid.

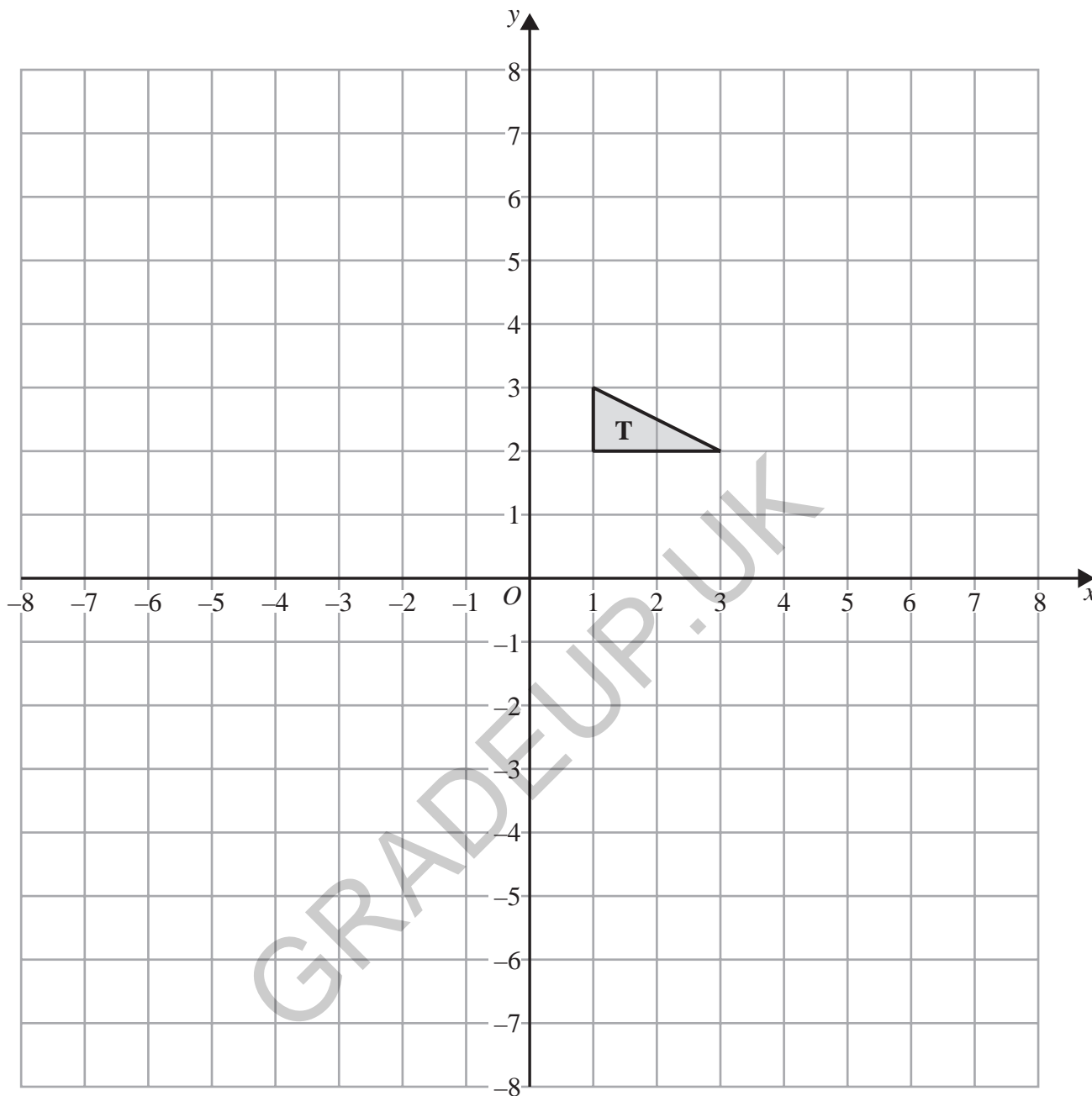

Enlarge triangle **T** by scale factor  $-2$  with centre of enlargement  $(0, 0)$

(Total for Question 12 is 2 marks)

DO NOT WRITE IN THIS AREA

DO NOT WRITE IN THIS AREA

DO NOT WRITE IN THIS AREA



P 7 6 9 2 7 A 0 1 3 2 4

- 13** There are 30 students in a class.  
A teacher is going to choose at random 2 of the students.

Work out the number of different pairs of students that the teacher can choose.

.....  
(Total for Question 13 is 2 marks)

- 14** At the start of 2022 Kim invested some money in a savings account.  
The account paid 3.5% compound interest each year.

At the end of 2022  
interest was added to the account then Kim took £750 from the account.

At the end of 2023  
interest was added to the account then Kim took £1000 from the account.

There was then £2937.14 in the account.

Work out how much money Kim invested at the start of 2022  
You must show all your working.

£.....

(Total for Question 14 is 4 marks)



DO NOT WRITE IN THIS AREA

DO NOT WRITE IN THIS AREA

DO NOT WRITE IN THIS AREA

15 (a) Simplify fully  $\frac{(a-3)^2}{5(a-3)}$

.....

(1)

(b) Factorise  $3k^2 + 11k - 4$

.....

(2)

(c) Simplify fully  $\frac{4-x^2}{x^2+3x} \div \frac{x+2}{x+3}$

.....

(3)

(Total for Question 15 is 6 marks)



P 7 6 9 2 7 A 0 1 5 2 4

16 The functions  $f$  and  $g$  are given by

$$f(x) = \frac{12}{x+1} \quad \text{and} \quad g(x) = 5 - 3x$$

(a) Find  $f(-3)$

.....  
(1)

(b) Find  $fg(1)$

.....  
(2)

(c) Find  $g^{-1}(4)$

.....  
(2)

(Total for Question 16 is 5 marks)

DO NOT WRITE IN THIS AREA

DO NOT WRITE IN THIS AREA

DO NOT WRITE IN THIS AREA



DO NOT WRITE IN THIS AREA

DO NOT WRITE IN THIS AREA

DO NOT WRITE IN THIS AREA

17 A ball is thrown upwards and reaches a maximum height.  
The ball then falls and bounces repeatedly.

After the  $n$ th bounce, the ball reaches a height of  $h_n$   
After the next bounce, the ball reaches a height given by  $h_{n+1} = 0.55h_n$

After the 1st bounce, the ball reaches a height of 8 metres.

What height does the ball reach after the 4th bounce?

..... metres

(Total for Question 17 is 3 marks)

GRADEUP.UK



18  $ABCD$  is a quadrilateral.

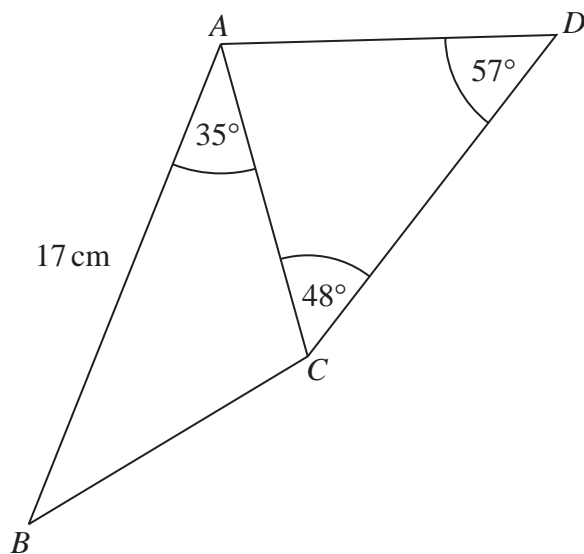

The area of triangle  $ABC$  is  $54\text{ cm}^2$

Calculate the area of triangle  $ACD$ .

Give your answer correct to 3 significant figures.

GRADEUP.UK

.....  $\text{cm}^2$

(Total for Question 18 is 5 marks)

DO NOT WRITE IN THIS AREA

DO NOT WRITE IN THIS AREA

DO NOT WRITE IN THIS AREA



DO NOT WRITE IN THIS AREA

DO NOT WRITE IN THIS AREA

DO NOT WRITE IN THIS AREA

19  $R = \frac{P}{Q}$

$P = 5.88 \times 10^8$  correct to 3 significant figures.

$Q = 3.6 \times 10^5$  correct to 2 significant figures.

Work out the lower bound for  $R$ .

Give your answer as an ordinary number correct to the nearest integer.

You must show all your working.

GRADEUP.UK

.....  
(Total for Question 19 is 3 marks)



20  $x - 4$ ,  $x + 2$  and  $3x + 1$  are three consecutive terms of an arithmetic sequence.

(a) Find the value of  $x$ .

$$x = \dots\dots\dots (2)$$

$y - 4$ ,  $y + 2$  and  $3y + 1$  are three consecutive terms of a geometric sequence.

(b) Find the possible values of  $y$ .

$$\dots\dots\dots (5)$$

(Total for Question 20 is 7 marks)



DO NOT WRITE IN THIS AREA

DO NOT WRITE IN THIS AREA

DO NOT WRITE IN THIS AREA

21 The diagram shows a circle, radius  $r$  cm and two regular hexagons.

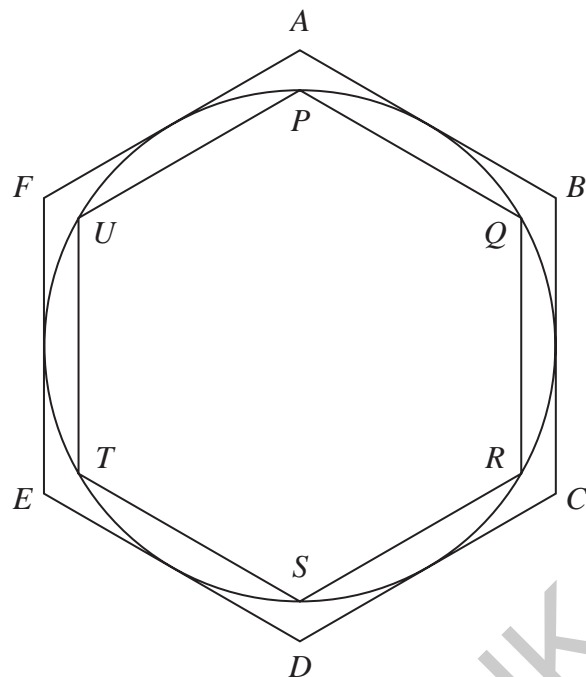

Each side of the larger hexagon  $ABCDEF$  is a tangent to the circle.  
Each side of the smaller hexagon  $PQRSTU$  is a chord of the circle.

By considering perimeters, show that

$$3 < \pi < 2\sqrt{3}$$

(Total for Question 21 is 4 marks)

TOTAL FOR PAPER IS 80 MARKS



DO NOT WRITE IN THIS AREA

DO NOT WRITE IN THIS AREA

DO NOT WRITE IN THIS AREA

GRADEUP.UK

**BLANK PAGE**



DO NOT WRITE IN THIS AREA

DO NOT WRITE IN THIS AREA

DO NOT WRITE IN THIS AREA

GRADEUP.UK

**BLANK PAGE**



DO NOT WRITE IN THIS AREA

DO NOT WRITE IN THIS AREA

DO NOT WRITE IN THIS AREA

GRADEUP.UK

BLANK PAGE

