

Monday 20 June 2022 – Morning

GCSE (9–1) Chemistry A (Gateway Science)

J248/02 Paper 2 (Foundation Tier)

Time allowed: 1 hour 45 minutes

You must have:

- a ruler (cm/mm)
- the Data Sheet for GCSE (9–1) Chemistry A (inside this document)

You can use:

- a scientific or graphical calculator
- an HB pencil



Please write clearly in black ink. **Do not write in the barcodes.**

Centre number

--	--	--	--	--

Candidate number

--	--	--	--

First name(s)

Last name

INSTRUCTIONS

- Use black ink. You can use an HB pencil, but only for graphs and diagrams.
- Write your answer to each question in the space provided. If you need extra space use the lined pages at the end of this booklet. The question numbers must be clearly shown.
- Answer **all** the questions.
- Where appropriate, your answer should be supported with working. Marks might be given for a correct method, even if the answer is wrong.

INFORMATION

- The total mark for this paper is **90**.
- The marks for each question are shown in brackets [].
- Quality of extended response will be assessed in questions marked with an asterisk (*).
- This document has **28** pages.

ADVICE

- Read each question carefully before you start your answer.

2
SECTION A

Answer **all** the questions.

You should spend a maximum of 30 minutes on this section.

Write your answer to each question in the box provided.

- 1 Chlorine and iodine are Group 7 elements.

	Chlorine	Iodine
A	green gas	purple gas
B	pale yellow gas	grey-black solid
C	green gas	grey-black solid
D	pale yellow gas	purple gas

Which row in the table describes these elements **at room temperature**?

Your answer

[1]

- 2 What is the test for oxygen gas?

- A Ignites with a squeaky pop.
- B Limewater turns milky.
- C Relights a glowing splint.
- D Turns damp blue litmus paper white.

Your answer

[1]

- 3 What is an enzyme?

- A A catalyst found in living organisms.
- B A man-made catalyst.
- C A non-biological catalyst.
- D A substance which makes a catalyst more efficient.

Your answer

[1]

4 Bromine water is used to test between ethane and ethene.

	Ethane	Ethene
A	bromine water is decolourised	no colour change
B	bromine water goes cloudy	bromine water is decolourised
C	bromine water goes clear	no colour change
D	no colour change	bromine water is decolourised

Which row in the table gives the correct test results?

Your answer

[1]

5 What is the displayed formula of **propanoic acid**?

A

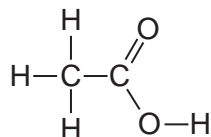

B

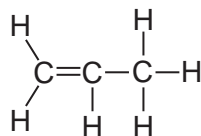

C

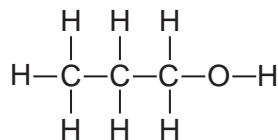

D

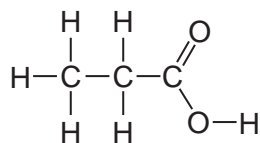

Your answer

[1]

- 6 DNA molecules are polymers made from monomers.

What are the monomers called?

- A Alkenes
- B Amino acids
- C Carbohydrates
- D Nucleotides

Your answer

[1]

- 7 Crude oil is separated into useful chemicals by fractional distillation.

The diagram shows the useful chemicals made in fractional distillation.

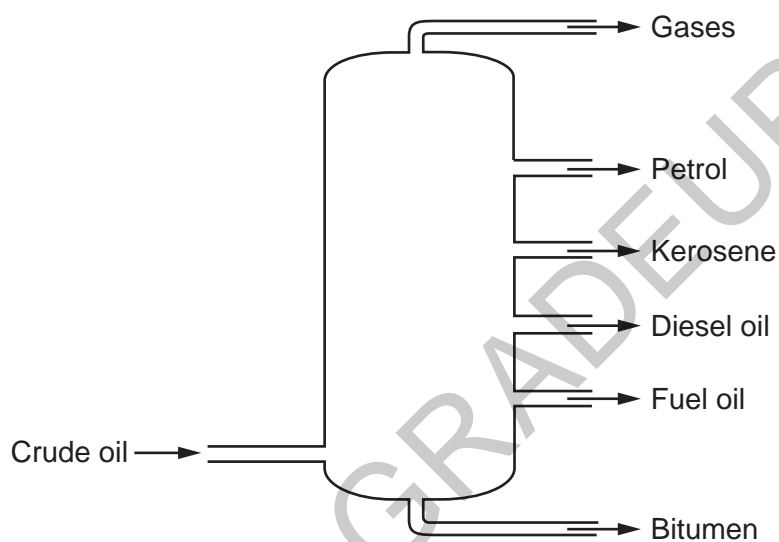

Which of these chemicals has the **largest** molecules?

- A Bitumen
- B Diesel oil
- C Gases
- D Petrol

Your answer

[1]

- 8 Which statement describes dynamic equilibrium?
- A Occurs in a closed system and the backward reaction is faster than the forward reaction.
 - B Occurs in a closed system and the forward reaction is faster than the backward reaction.
 - C Occurs in a closed system and the rates of the forward and backward reactions are equal.
 - D Occurs in an open system and the rates of the forward and backward reactions are equal.

Your answer

[1]

- 9 The rate of the reaction between marble chips and dilute hydrochloric acid is increased by breaking the marble chips into smaller pieces.

Why does this increase the rate of reaction?

- A The marble chips act as a catalyst.
- B The marble chips have a greater concentration.
- C The marble chips have a larger surface area.
- D The marble chips move faster.

Your answer

[1]

- 10 Copper carbonate, CuCO_3 , decomposes when heated.

Copper oxide, CuO , is made. Carbon dioxide is a waste product.



What is the **atom economy** of the reaction?

Relative molecular mass (A_r): $\text{CuCO}_3 = 123.5$ $\text{CuO} = 79.5$ $\text{CO}_2 = 44.0$

- A 28.7%
- B 35.6%
- C 64.4%
- D 155.3%

Your answer

[1]

11 The list shows the reactivity series of some metals.

The non-metal element carbon is also included.

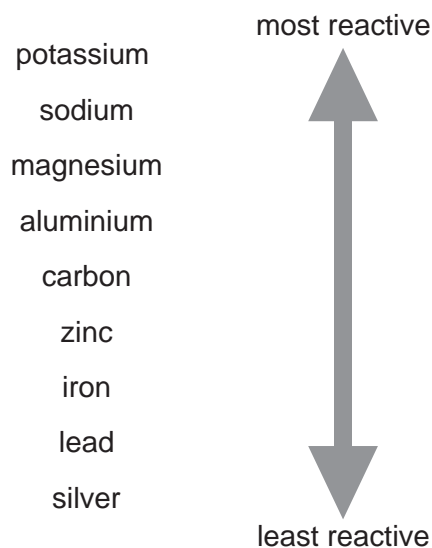

	Extracted from its ore by electrolysis	Extracted from its ore by heating with carbon
A	magnesium	silver
B	silver	potassium
C	sodium	aluminium
D	zinc	aluminium

Which row in the table is correct?

Your answer

[1]

12 Why is magnesium more reactive with dilute acids than zinc?

- A** Magnesium forms positive ions more easily than zinc.
- B** Magnesium forms negative ions more easily than zinc.
- C** Magnesium gains electrons more easily than zinc.
- D** Magnesium gains hydrogen more easily than zinc.

Your answer

[1]

13 What is the test for halide ions?

- A Add a few drops of dilute nitric acid then a few drops of silver nitrate solution.
- B Add a few drops of hydrochloric acid then a few drops of barium chloride solution.
- C Add a few drops of hydrochloric acid then a few drops of silver nitrate solution.
- D Add a few drops of sodium hydroxide solution.

Your answer

[1]

14 Large molecules produced by fractional distillation are cracked to make smaller molecules.

Octane, C_8H_{18} , is cracked to form ethene, C_2H_4 , and one other product.

What is the formula of the other product?

- A C_3H_6
- B C_6H_{12}
- C C_6H_{14}
- D C_8H_{16}

Your answer

[1]

15 Dilute hydrochloric acid reacts with marble chips.

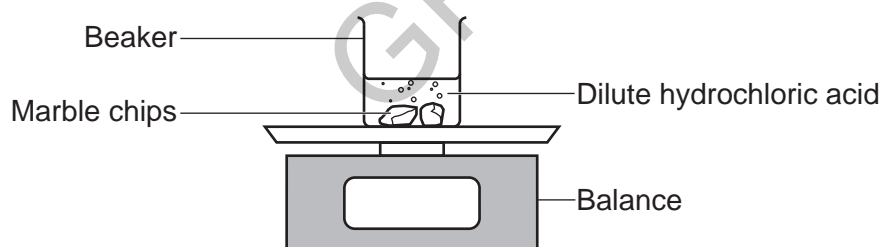

Which statement about the reaction is correct?

- A The reaction is faster after 10 seconds than it is after 3 seconds.
- B The reaction slows down with time.
- C The reaction proceeds at a constant rate.
- D The mass of the beaker and its contents stay the same.

Your answer

[1]

8
SECTION B

Answer **all** the questions.

16 The table shows information about some compounds of carbon.

Compound	Formula
A	CH ₄
B	C ₂ H ₄
C	C ₂ H ₆
D	C ₃ H ₆
E	C ₃ H ₈

(a) Some of the compounds belong to the homologous series called the **alkanes**.

Which hydrocarbons are alkanes?

Tick (✓) **three** boxes.

A

B

C

D

E

[3]

(b) Which homologous series do the compounds which are **not** alkanes belong to?

Tick (✓) **one** box.

Alcohols

Alkenes

Carboxylic acids

Esters

[1]

(c) Compound **B**, C₂H₄, burns completely in oxygen.

State the names of the **two products** of this reaction.

..... and [2]

(d) Compound **A** is obtained from crude oil by fractional distillation.

Complete the sentences about fractional distillation. Use words from the list.

cracked	colder	condense	evaporate
fractions	heated	hotter	polymers

Crude oil is as it enters a fractionating column. The vapours get as they rise. The vapours to a liquid at different points. The separated parts of crude oil are called [4]

(e) Crude oil is a finite resource.

Explain what is meant by a **finite resource**.

.....
 [1]

- 17 A student neutralises 6.00 g of nitric acid, HNO_3 , with ammonia, NH_3 , to make ammonium nitrate, NH_4NO_3 .

The equation shows this reaction.

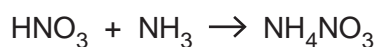

- (a) Calculate the **theoretical yield** of ammonium nitrate, NH_4NO_3 .

Give your answer to **3** significant figures.

Relative atomic mass (A_r): H = 1.0 N = 14.0 O = 16.0.

Theoretical yield of ammonium nitrate = g [4]

- (b) The **atom economy** for the reaction between nitric acid and ammonia is 100%.

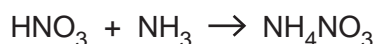

Use the balanced symbol equation to explain why the atom economy is 100%.

.....
 [1]

- (c) In another reaction, the student makes 4.0 g of ammonium sulfate.

They predicted that they should have made 6.6 g.

Calculate their **percentage yield**.

Give your answer to **2** significant figures.

Percentage yield = % [3]

18 A car manufacturer is concerned about the carbon dioxide, CO₂, emissions of different cars during their lifetime.

The car manufacturer does a life-cycle assessment for three types of car they are developing:

- a petrol car
- a diesel car
- an electric car.

(a) What is the car manufacturer working out in these life-cycle assessments?

Tick (✓) **one** box.

The potential amount of fuel used by the car.

The potential cost of each stage of the life of the car.

The potential environmental impact at each stage of the life of the car.

The potential health and safety issues at each stage of the life of the car.

[1]

(b) The graph shows the life-cycle assessment for the three types of car.

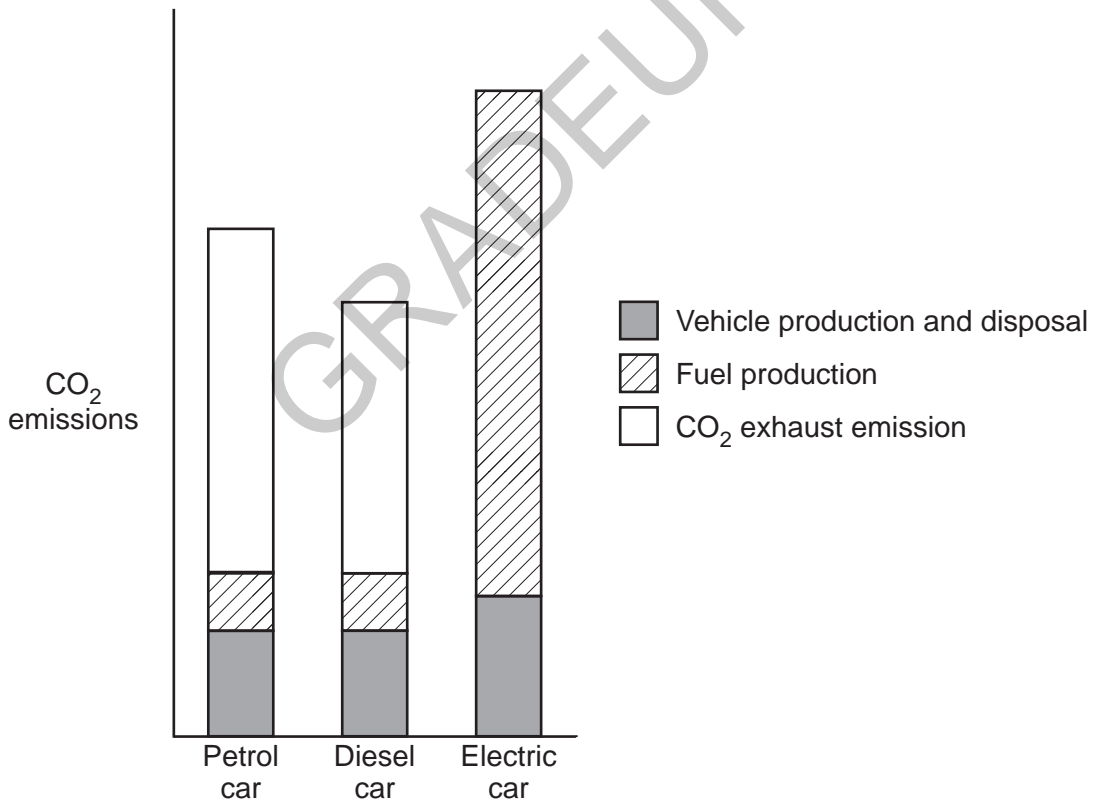

(i) Which type of car produces the most carbon dioxide exhaust emissions?

Tick (✓) **one** box.

- Petrol car
- Diesel car
- Electric car

[1]

(ii) Which type of car produces the most carbon dioxide over its lifetime?

Tick (✓) **one** box.

- Petrol car
- Diesel car
- Electric car

[1]

(c) Describe **two** potential problems of increased levels of carbon dioxide in the Earth's atmosphere.

- 1
-
- 2
-

[2]

(d) The electricity used to charge the electric car can be produced by burning coal which produces a large amount of carbon dioxide.

The amount of carbon dioxide produced is reduced by 95% if the electricity is generated in a different way.

Suggest how the electricity used to charge the car can be generated, other than by burning coal.

-
- [1]

19 The table shows information about three metals.

Metal	Corrosion in moist air	Density (g/cm ³)	Electrical conductivity	Melting point (°C)
aluminium	no obvious corrosion	2.7	good	660
copper	corrodes slowly	9.0	excellent	1084
iron	corrodes quickly	7.9	good	1538

(a) A student thinks that **aluminium** would be the best metal to use to make a model helicopter.

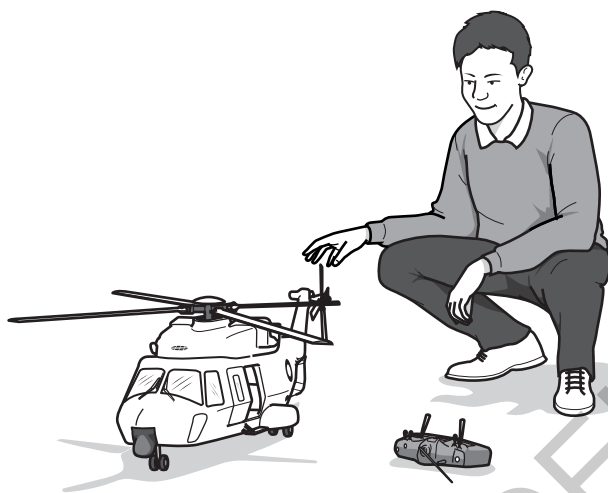

Explain why the student is correct. Use information from the table.

.....

.....

..... [2]

(b) The wire inside the cable used to charge a mobile phone is made of a metal.

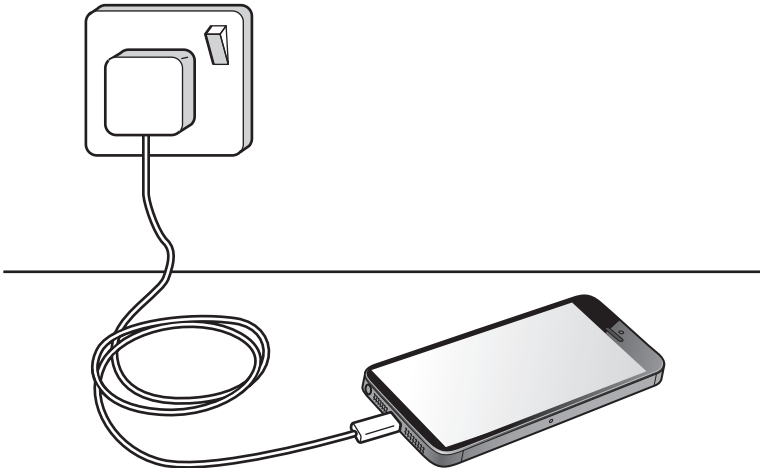

Which of the three metals would you choose to make the wire inside the cable used to charge a mobile phone?

Explain your answer.

Metal

Explanation

.....

..... [3]

GRADEUP.UK

(c) Poly(chloroethene) is a polymer used to make gutters.

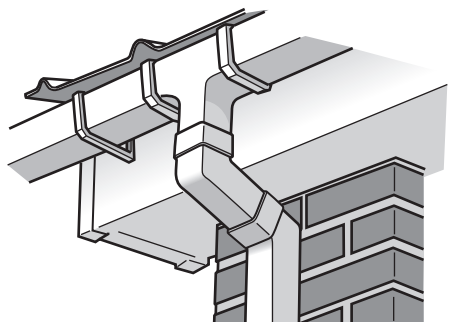

Poly(chloroethene) has a melting point of 165 °C.

The melting point of aluminium is 660 °C.

Calculate the ratio of the melting point of poly(chloroethene) to the melting point of aluminium.

Ratio = [2]

(d) In the past gutters were made from iron.

Suggest why poly(chloroethene) is a better material than iron for making gutters.

.....

.....

..... [2]

(e) Poly(chloroethene) is a polymer made from the monomer chloroethene.

This is the structure of chloroethene.

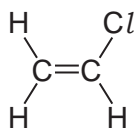

(i) Explain why chloroethene is **not** a hydrocarbon.

.....
..... [1]

(ii) Complete the diagram to show the displayed formula of the polymer poly(chloroethene).



[2]

20 Atmospheric pollution can be caused by

- carbon monoxide
- oxides of nitrogen
- sulfur dioxide.

(a) Explain why **carbon monoxide** in the atmosphere is a problem.

.....

.....

..... [2]

(b) Sulfur dioxide causes acid rain.

Why is acid rain a problem?

..... [1]

(c) The pie chart shows different sources of emissions of oxides of nitrogen.

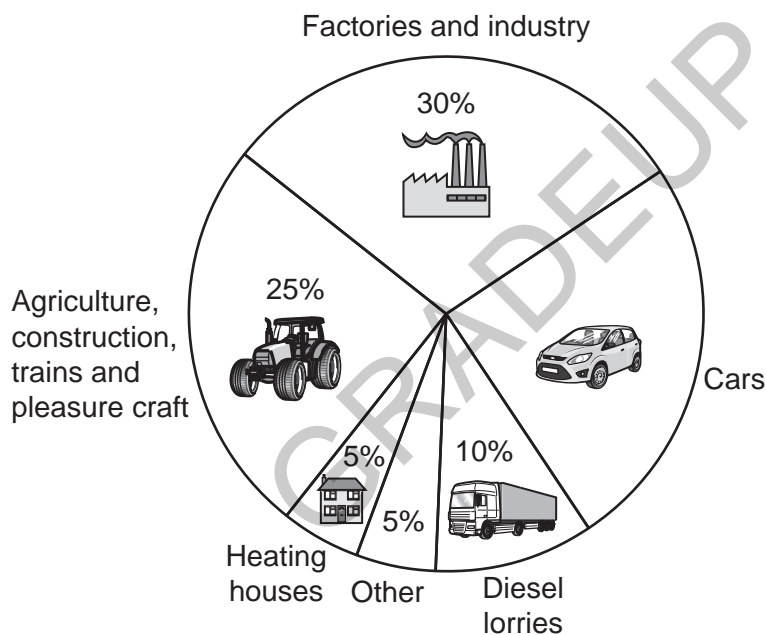

(i) Calculate the percentage emissions of oxides of nitrogen from cars.

Percentage emissions of oxides of nitrogen from cars = % [1]

(ii) What is the **largest** source of emissions of oxides of nitrogen?

..... [1]

- (d) A catalytic converter on a car removes nitrogen monoxide and carbon monoxide from exhaust gases.

Nitrogen gas and carbon dioxide gas are made.

This is the equation for the reaction that takes place.

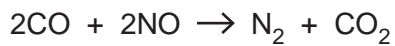

On a car journey 1.4 tonnes of nitrogen is made.

Calculate the **mass of nitrogen monoxide** removed from the exhaust gases.

Relative atomic mass (A_r): N = 14.0 O = 16.0.

Mass of nitrogen monoxide = tonnes [3]

21
BLANK PAGE

PLEASE DO NOT WRITE ON THIS PAGE

GRADEUP.UK

22 Hydrogen peroxide, H_2O_2 , is used as a source of oxygen gas.

Hydrogen peroxide decomposes to make oxygen gas, O_2 , and water.

(a) Write the **balanced symbol** equation for this reaction.

..... [2]

(b) The decomposition of hydrogen peroxide is very slow at room temperature. The reaction can be speeded up by adding a catalyst.

- A student investigates the decomposition of hydrogen peroxide using two different catalysts, **A** and **B**.
- The student uses 50 cm^3 of hydrogen peroxide and 0.5 g of the catalyst in each experiment.

The table shows the student's results.

Time (minutes)	Volume of oxygen (cm^3)	
	Catalyst A	Catalyst B
0	0.0	0.0
5	4.0	5.0
10	8.0	10.0
15	12.0	15.0
20	16.0	16.5
25	17.5	18.0
30	18.0	18.0
35	18.0	18.0

The results for catalyst **A** are shown on **Fig. 22.1**.

Plot the results for catalyst **B** on **Fig. 22.1** and draw a line of best fit.

[2]

Fig. 22.1

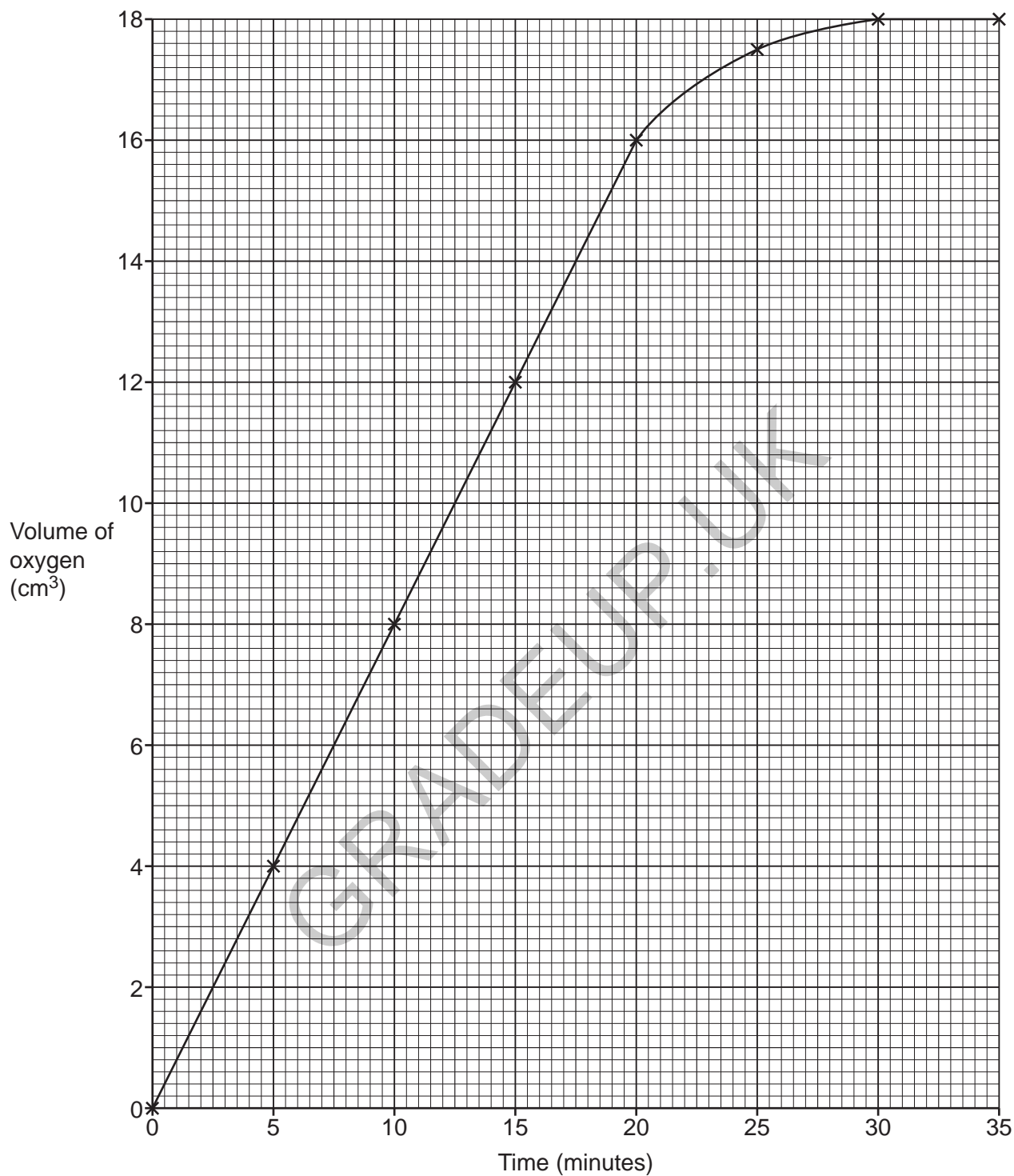

(c) The student thinks catalyst **B** is the better catalyst.

Explain why the student is correct. Use data from the graph.

.....

.....

..... [2]

- (d) The volume of oxygen made in each experiment is 18 cm³.

Explain why it is the same value.

.....
..... [1]

- (e) The student repeats the experiment with **1.0 g** of catalyst **A** instead of 0.5 g.

What is the volume of oxygen gas made at the end of the experiment?

Volume of oxygen gas = cm³ [1]

- (f) The student thinks the decomposition of hydrogen peroxide will be faster at 30 °C than at room temperature.

Describe an experiment the student could do, and its results, to show the reaction is faster at 30 °C.

.....
.....
.....
.....
..... [3]

GRADEUP.UK

23 A teacher investigates the reactions of copper carbonate, CuCO_3 .

The diagram shows the reactions the teacher does.

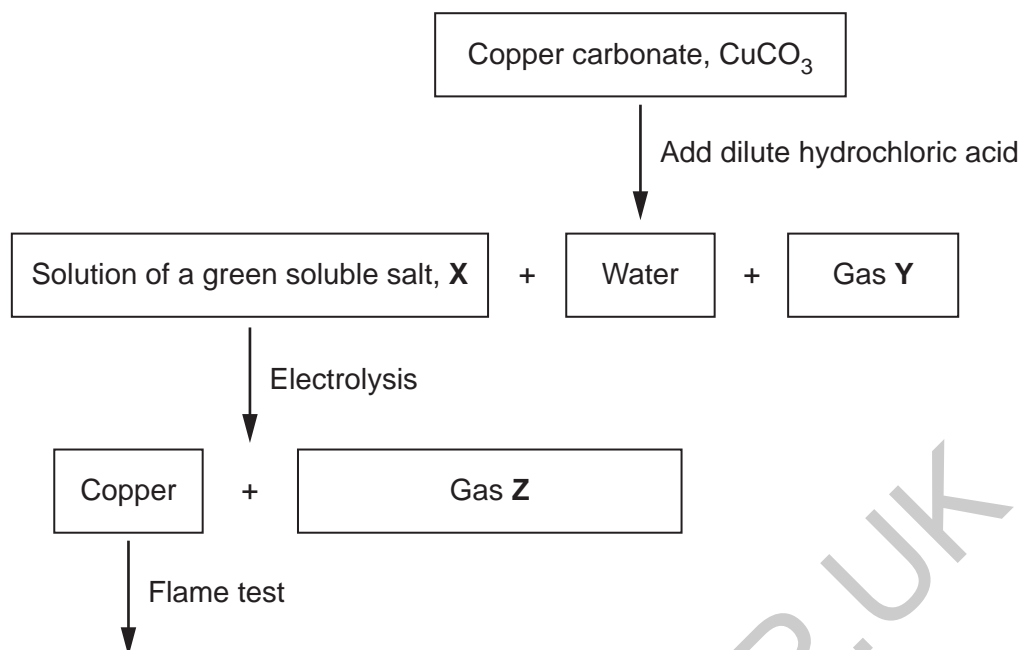

(a) State the name of the soluble salt, **X**.

..... [1]

(b) State the name of gas **Y**.

..... [1]

(c) Gas **Z** turns damp blue litmus paper white.

State the name of gas **Z**.

..... [1]

(d) The teacher performs a flame test of the copper made by the electrolysis of **X**.

What colour flame does the teacher observe?

..... [1]

- (e) Copper metal is extracted from copper oxide by heating with carbon as shown in the equation.



Explain why copper is extracted.

Use ideas about the reactivity series.

.....
 [1]

- (f) Copper is used to make useful alloys.

The table gives information about some copper alloys.

Alloy	Main metals	Uses
duralumin	copper and	aircraft parts
brass	copper and	♦ musical instruments
bronze	copper and tin

Complete the table.

[2]

END OF QUESTION PAPER

ADDITIONAL ANSWER SPACE

If additional space is required, you should use the following lined page(s). The question number(s) must be clearly shown in the margin(s).

A large area of the page is filled with horizontal dotted lines, providing space for writing answers. A vertical solid line is positioned on the left side of this area, creating a margin. A large, light grey watermark reading "GRADEUP.UK" is oriented diagonally across the center of the page.

Blank writing area with horizontal dotted lines and a vertical solid line on the left side.

GRADEUP.UK

OCR

Oxford Cambridge and RSA

Copyright Information

OCR is committed to seeking permission to reproduce all third-party content that it uses in its assessment materials. OCR has attempted to identify and contact all copyright holders whose work is used in this paper. To avoid the issue of disclosure of answer-related information to candidates, all copyright acknowledgements are reproduced in the OCR Copyright Acknowledgements Booklet. This is produced for each series of examinations and is freely available to download from our public website (www.ocr.org.uk) after the live examination series.

If OCR has unwittingly failed to correctly acknowledge or clear any third-party content in this assessment material, OCR will be happy to correct its mistake at the earliest possible opportunity.

For queries or further information please contact The OCR Copyright Team, The Triangle Building, Shaftesbury Road, Cambridge CB2 8EA.

OCR is part of Cambridge University Press & Assessment, which is itself a department of the University of Cambridge.