

Friday 27 May 2022 – Morning

GCSE (9–1) Chemistry B (Twenty First Century Science)

J258/01 Breadth in Chemistry (Foundation Tier)

Time allowed: 1 hour 45 minutes

You must have:

- a ruler (cm/mm)
- the Data Sheet for GCSE (9–1) Chemistry B (inside this document)

You can use:

- an HB pencil
- a scientific or graphical calculator



Please write clearly in black ink. **Do not write in the barcodes.**

Centre number

--	--	--	--	--

Candidate number

--	--	--	--

First name(s)

Last name

INSTRUCTIONS

- Use black ink. You can use an HB pencil, but only for graphs and diagrams.
- Write your answer to each question in the space provided. If you need extra space use the lined pages at the end of this booklet. The question numbers must be clearly shown.
- Answer **all** the questions.
- Where appropriate, your answer should be supported with working. Marks might be given for using a correct method, even if your answer is wrong.

INFORMATION

- The total mark for this paper is **90**.
- The marks for each question are shown in brackets [].
- This document has **28** pages.

ADVICE

- Read each question carefully before you start your answer.

Answer **all** the questions.

1 Earth's early atmosphere contained mostly carbon dioxide and water vapour.

(a) As the Earth cooled, water vapour turned to liquid water and the oceans formed.

Complete the sentence to explain why the oceans formed.

Put a ring around the correct answer.

The oceans formed because the water vapour **boiled / condensed / evaporated / froze**. [1]

(b) Gradually, plants began to grow on the Earth.

Complete the sentences to describe how an oxygen-rich atmosphere has developed over time.

Use words from the list.

carbon dioxide	combustion	methane	nitrogen	photosynthesis
-----------------------	-------------------	----------------	-----------------	-----------------------

Plants make oxygen in a process called

This process uses a gas called

[2]

- (c) The graph shows how the percentage of carbon dioxide in the atmosphere has changed over time.

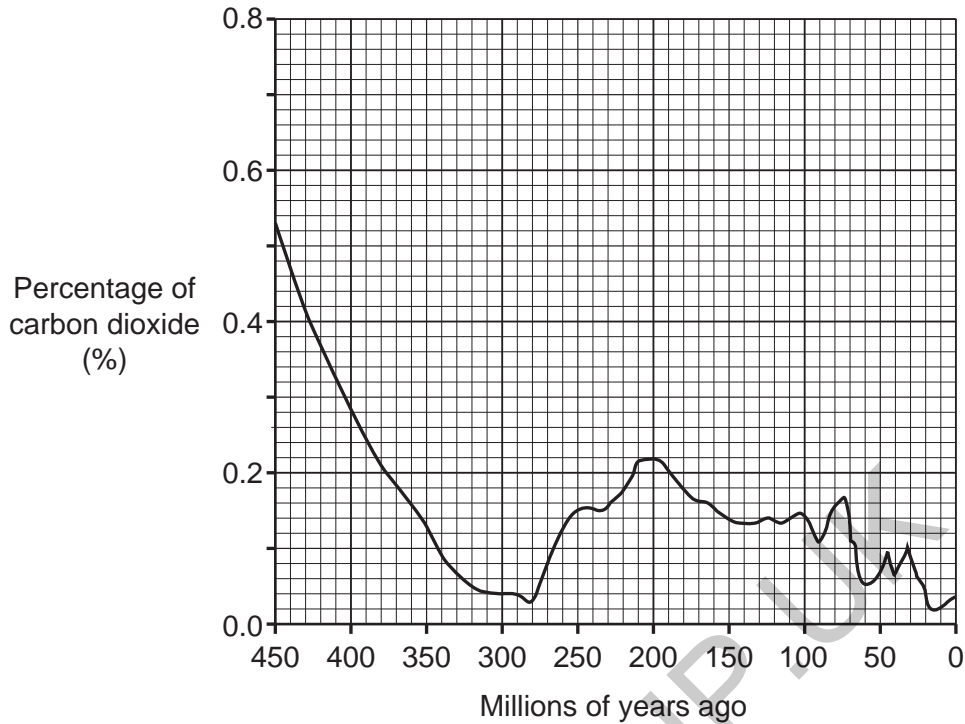

- (i) Describe how the percentage of carbon dioxide in the atmosphere has changed over the last 300 million years.

Use data from the graph in your answer.

.....

.....

.....

..... [2]

- (ii) State the percentage of carbon dioxide in the atmosphere 200 million years ago.

Percentage = % [1]

- (iii) 400 million years ago there was 0.28% carbon dioxide in the atmosphere.

Today there is 0.04%.

Calculate how many times more carbon dioxide there was 400 million years ago compared with today.

There was times more carbon dioxide 400 million years ago. [1]

- 2 (a) Complete the sentence to describe how Mendeleev placed elements in the Periodic Table.

Use words from the list.

atomic	colour	molecular	properties	size
--------	--------	-----------	------------	------

Mendeleev organised the elements based on their and their relative masses.

[2]

- (b) Table 2.1 shows the properties of some elements.

Name	Atomic number	Melting point (°C)	Appearance	Electrical conductivity
Lithium	3	181	shiny when cut	good
Boron	5	2076	black	poor
Magnesium	12	650	shiny	good
Phosphorus	15	44	white/yellow	poor

Table 2.1

- (i) Which **two** elements in Table 2.1 are metals?

..... and [1]

- (ii) Which **column** in Table 2.1 did you use to work out your answer to (b)(i)?

..... [1]

- (iii) The elements in Table 2.1 are all solids at room temperature (25 °C).

How does the data in the table show that this is true?

.....
 [1]

- (iv) What does atomic number tell you about the nucleus of an atom?

.....
 [1]

(c) Iodine and chlorine are halogens in Group 17 (Group 7).

(i) Draw lines to connect each **halogen** with its correct **appearance** at room temperature (25 °C).

Halogen	Appearance
Chlorine	Grey solid
Iodine	Purple gas
	Green gas
	Brown liquid

[2]

(ii) Sodium iodide solution reacts with chlorine.

Complete the word equation for this reaction.

sodium iodide + chlorine → iodine +

[1]

3 'Cool packs' containing ammonium nitrate are used to treat sports injuries.

(a) Ammonium nitrate absorbs energy when it dissolves in water.
The temperature of the water falls.

(i) Which energy level diagram shows the energy change when ammonium nitrate dissolves in water?

Tick (✓) **one** box.

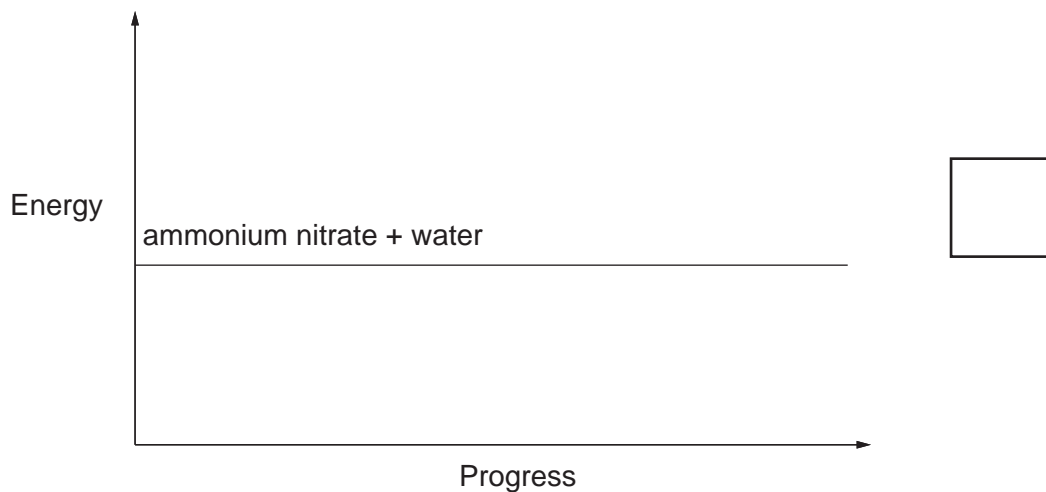
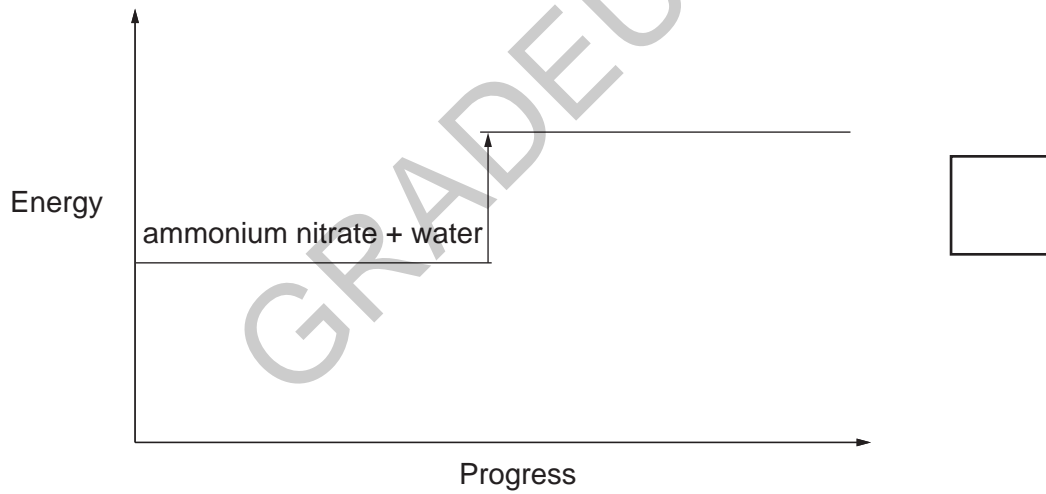
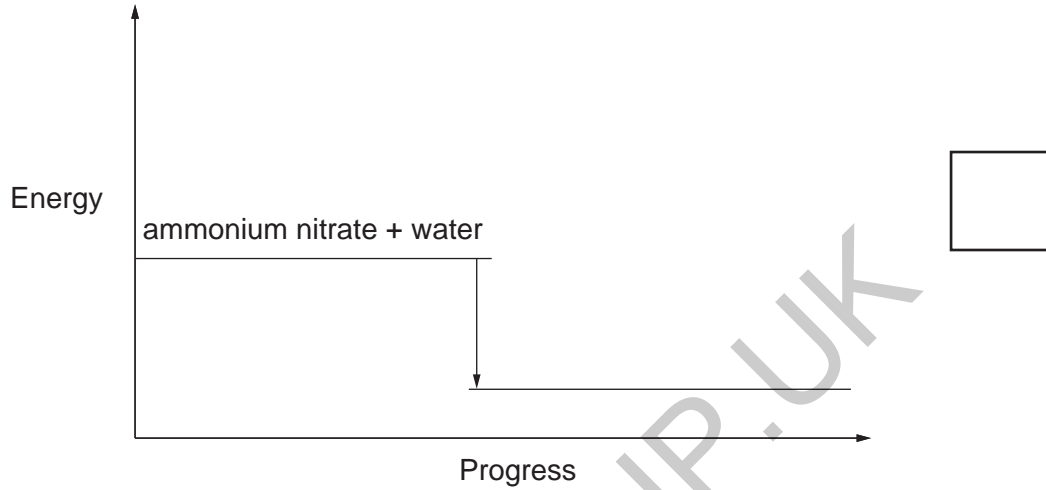

4 Crude oil contains many alkanes. The table shows some of these alkanes:

Alkane	Formula	Relative formula mass	Boiling point (°C)
Heptane	C_7H_{16}	100	98
Octane	C_8H_{18}	114	126
Decane	$C_{10}H_{22}$	142	174
Undecane	$C_{11}H_{24}$	156	196

(a) The graph shows how boiling point changes with relative formula mass for three of the alkanes.

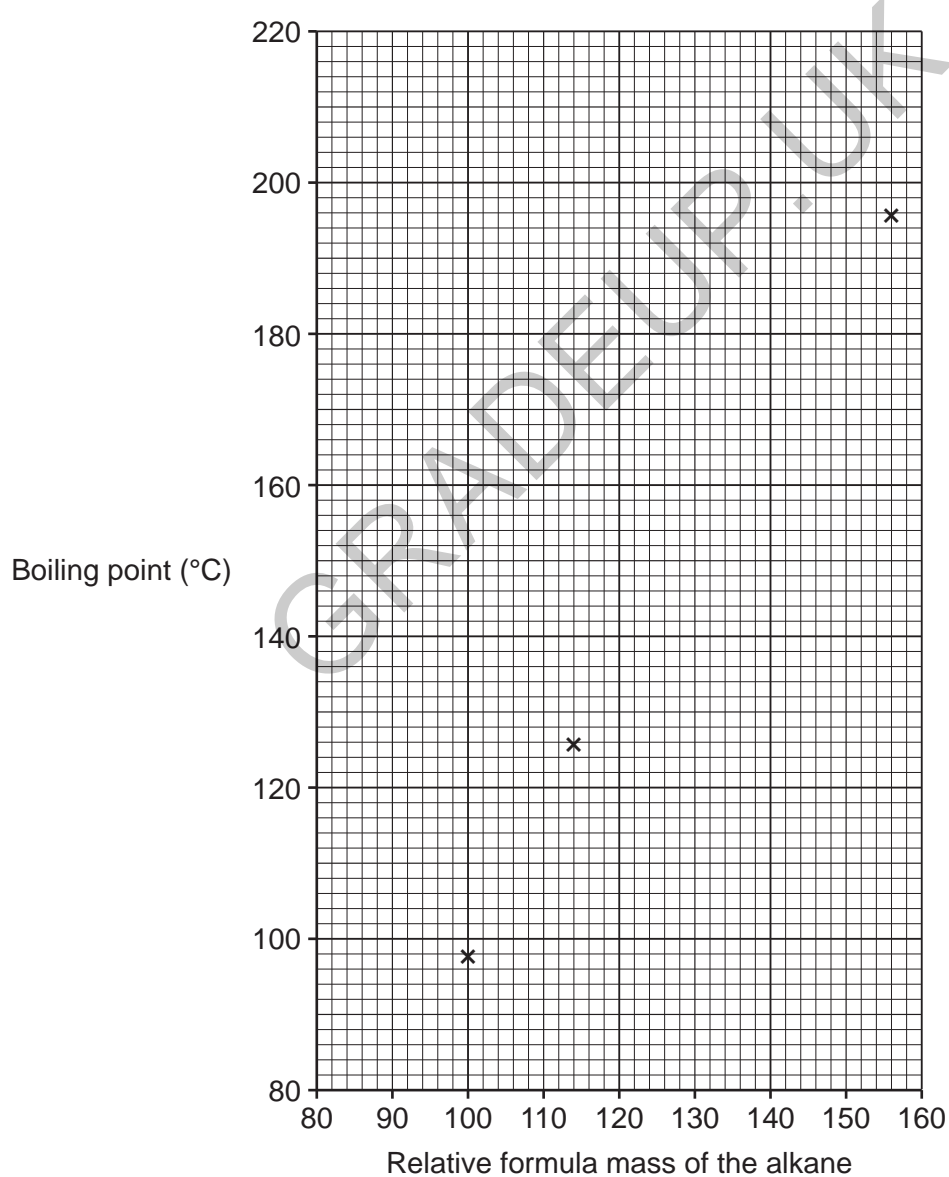

(i) Plot the point for decane on the graph.

[1]

(ii) Draw a line of best fit.

[1]

(iii) The relative formula mass of C_9H_{20} is 128.

Use the graph to estimate the boiling point of C_9H_{20} .

Boiling point of C_9H_{20} = °C [1]

(b) (i) The general formula of alkanes is C_nH_{2n+2} . Pentane has five carbon atoms.

State the formula of pentane.

..... [1]

(ii) Complete the word equation for the reaction when pentane burns completely in oxygen.

pentane + oxygen \rightarrow carbon dioxide + [1]

(c) (i) What is the **simplest** ratio of carbon atoms to hydrogen atoms in ethane (C_2H_6)?

Simplest ratio of carbon atoms : hydrogen atoms = : [1]

(ii) State the empirical formula of ethane (C_2H_6).

Empirical formula [1]

(d) Complete the sentences to describe C–C bonds.

Use words from the list.

covalent	given	ionic	shared
----------	-------	-------	--------

C–C bonds are

The electrons between the carbon atoms are

[2]

(e) Ethanol, C_2H_5OH can be made from crude oil.

Why is the OH group in ethanol called the **functional group**?

Tick (✓) **one** box.

It contains an oxygen atom.

It is at one end of the molecule.

It contains a covalent bond.

It gives ethanol its chemical properties.

[1]

5 This question is about the reactivity of metals.

(a) Magnesium reacts with iron sulfide.

magnesium + iron sulfide \rightarrow iron + magnesium sulfide

- (i) The formula for iron sulfide is FeS.
The formula for magnesium sulfide is MgS.

Write a **balanced symbol** equation for this reaction.

..... [1]

(ii) How does this reaction show that magnesium is above iron in the reactivity series?

.....
..... [1]

(b) Complete the sentences about the reactivity of metals with acids.

Use words from the list.

electrons	protons	quickly	slowly
-----------	---------	---------	--------

Metals higher in the reactivity series react with acids more

This is because they form positive ions more easily by losing

[2]

11
BLANK PAGE

PLEASE DO NOT WRITE ON THIS PAGE

GRADEUP.UK

- 6 (a) Iron ore contains iron oxide. Iron ore reacts with carbon to make iron.
This is a word equation for the reaction:



Which statement describes this reaction?

Tick (✓) **one** box.

Iron is oxidised.

Carbon is reduced.

Iron oxide is reduced.

Carbon monoxide is oxidised.

[1]

- (b) 160g of iron oxide makes 112g of iron.

Calculate the mass of iron in 100g of iron oxide.

Mass of iron = g [2]

- (c) Iron is used to make steel.

Complete the sentences about steel.

Use words from the list.

alloys	aluminium	carbon	ceramics	polymers
--------	-----------	--------	----------	----------

Steel contains atoms of iron and

Steel is an example of materials known as

[2]

(d) The main disadvantage of using steel is that it rusts.

Complete the sentences about rusting.

Use words from the list.

barrier	carbon dioxide	nitrogen	reduction	solution	water
----------------	-----------------------	-----------------	------------------	-----------------	--------------

Steel rusts when it reacts with oxygen and

Rusting can be prevented by covering the steel with grease,

which forms a

[2]

(e) Used steel is collected and recycled.

Which statements about recycling are advantages and which are disadvantages?

Tick (✓) **one** box in each row.

	Advantage	Disadvantage
Recycling steel uses much less energy than making iron and steel from iron ore.		
Materials must be collected and sorted in recycling.		
Raw materials (metal ores) are not used in recycling.		

[2]

7 Jack adds the **same** volume of dilute sulfuric acid to three different samples of solid zinc carbonate.

(a) Complete the sentence.

The gas made when the reaction fizzes is called carbon [1]

(b) Here are Jack's results:

Experiment	Mass of zinc carbonate (g)	Type of zinc carbonate	Time to stop fizzing (minutes)
1	2.0	lumps	10
2	2.0	powder	6
3	4.0	lumps	

(i) Jack looks at his results from **Experiment 1** and **Experiment 2**.

How do the results of these two experiments show that the powder reacts faster than the lumps?

.....
..... [1]

(ii) Explain why the powder reacts **faster** than the lumps.

Use ideas about particles in your answer.

.....
.....
.....
..... [2]

(c) What is the most likely time taken for **Experiment 3**?

Tick (✓) **one** box.

Less than 6 minutes.

6 minutes.

Between 6 and 10 minutes.

10 minutes.

Longer than 10 minutes.

[1]

(d) At the end of **Experiment 2**, the mixture formed contains a solution of zinc sulfate with some unreacted solid zinc carbonate.

Jack filters the mixture to remove the unreacted solid zinc carbonate.

Describe how Jack can obtain a sample of zinc sulfate crystals from the solution.

.....

.....

.....

.....

..... [2]

(e) Jack makes 6.6 g of zinc sulfate. He calculates that he should have made 9.8 g.

Calculate the percentage yield.

Give your answer to **2** significant figures.

Use the equation: $\text{percentage yield} = \frac{\text{actual yield}}{\text{theoretical yield}} \times 100$

Percentage yield = % [3]

- 8 Sara compares two drain cleaners called 'Drainclear' and 'Noblock'. Both drain cleaners contain a solution of sodium hydroxide.

Sara titrates the **same** volume of each drain cleaner with the **same** concentration of dilute hydrochloric acid.

- (a) Which word describes the reaction between sodium hydroxide and hydrochloric acid?

Tick (✓) **one** box.

Oxidation

Reduction

Neutralisation

Condensation

[1]

- (b) This is a diagram of Sara's apparatus:

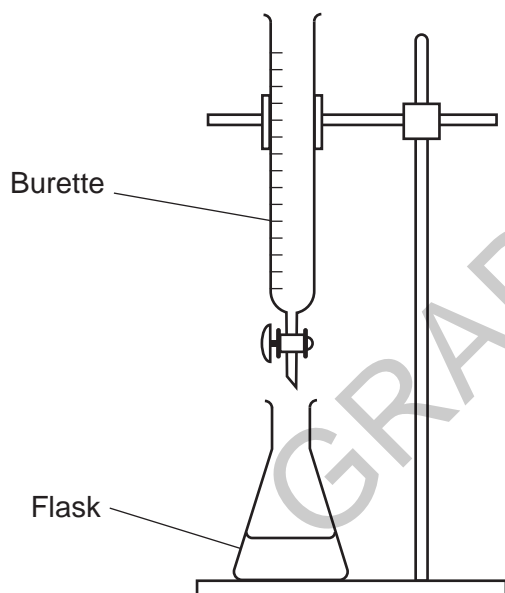

This is Sara's method:

- Put 25.0 cm³ of drain cleaner into the flask.
- Add an indicator to the drain cleaner.

Write down the next **two** steps of Sara's method to get to the end-point of the titration.

1

.....

2

.....

[2]

(c) Here are Sara's results:

Drain cleaner	Accurate titration results (cm ³)			Mean volume of hydrochloric acid (cm ³)
Drainclear	6.85	6.80	6.75	6.80
Noblock	20.45		20.35	20.40

(i) Calculate the missing titration result for Noblock.

Answer = cm³ [1]

(ii) Look at the mean volume of hydrochloric acid used for each drain cleaner.

What can you conclude about the amount of sodium hydroxide in Drainclear and Noblock?

Give **one** reason for your answer.

Conclusion

.....

Reason

.....

[2]

- 9 (a) When molten compounds are electrolysed:
- the metal is made at the negative electrode
 - the non-metal is made at the positive electrode.

State what is made at each electrode when **molten** aluminium oxide is electrolysed.

Negative electrode

Positive electrode

[2]

- (b) Nina electrolyses sodium chloride **solution**, using inert (unreactive) electrodes.

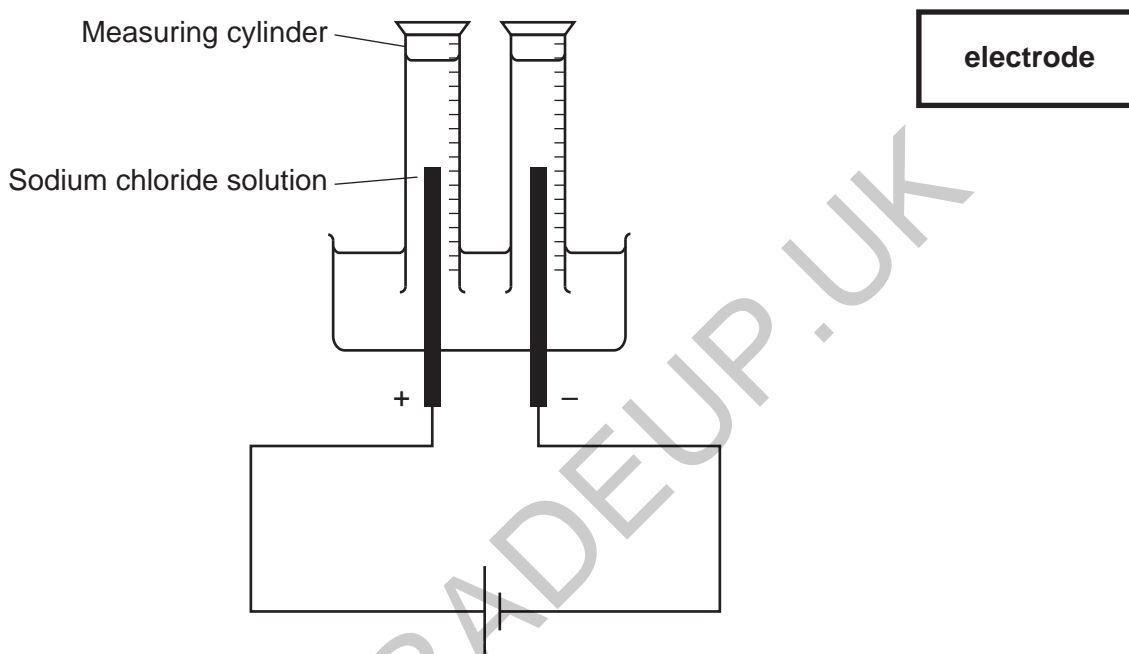

- (i) Draw a line to connect the box labelled **electrode** with the correct part of the diagram. [1]

- (ii) Explain why Nina places a measuring cylinder containing sodium chloride solution over each electrode.

.....

 [2]

- (iii) Sodium is **not** made at the negative electrode when sodium chloride solution is electrolysed.

Name the gas made at the negative electrode.

..... [1]

10 Jamal has a sample of copper sulfate crystals.

The copper sulfate crystals have been accidentally mixed with graphite powder. Graphite is a form of carbon.

(a) Jamal dissolves the sample of copper sulfate crystals in water.

(i) Complete the sentence to explain why graphite can be separated by filtering it out.

Use **one** word from the list.

aqueous	insoluble	non-aqueous	soluble
---------	-----------	-------------	---------

Graphite can be separated by filtering it out because graphite is
in water.

[1]

(ii) Jamal is using mixtures and pure substances.

Complete **Table 10.1** to identify which are mixtures and which are pure substances.

Tick (✓) **one** box in each row.

	Mixture	Pure substance
Copper sulfate crystals		
Graphite powder		
Copper sulfate mixed with graphite powder		

Table 10.1

[2]

(b) **Table 10.2** shows **two** tests Jamal does on the copper sulfate solution:

Test	Result
Add sodium hydroxide solution
Add acidified barium chloride solution

Table 10.2

Complete the results in **Table 10.2** by writing what Jamal sees when he does the tests.

[2]

- 11 Mia investigates the rate of reaction when zinc reacts with dilute sulfuric acid. She adds zinc pieces to dilute sulfuric acid at room temperature.

Fig. 11.1 shows the apparatus she uses:

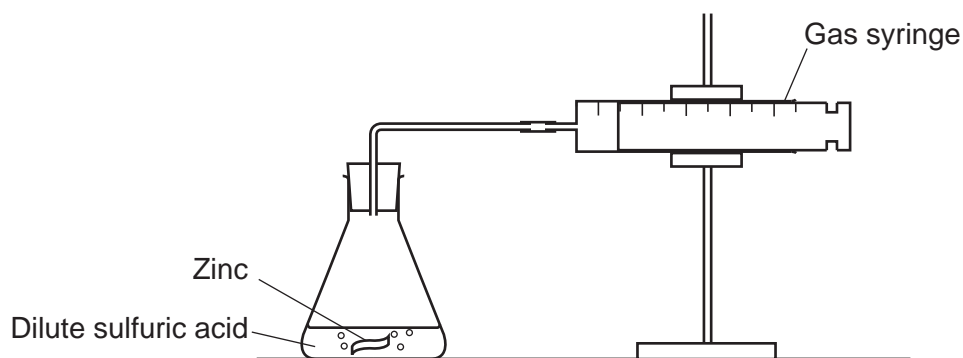
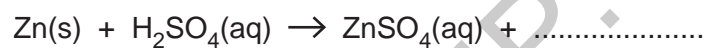

Fig. 11.1

- (a) Complete the symbol equation for the reaction.

Include a **state symbol**.



[2]

- (b) Mia measures the volume of gas in the gas syringe every two minutes.

Fig. 11.2 shows a graph of her results:

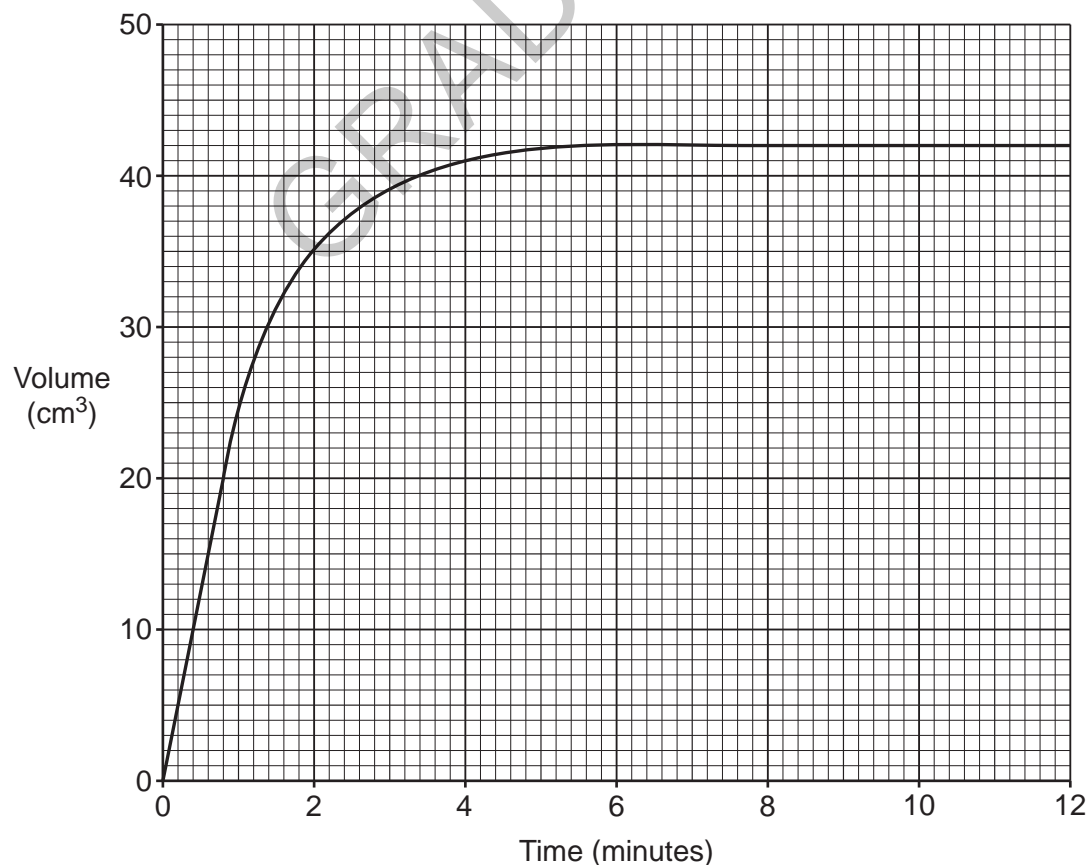

Fig. 11.2

21

- (i) Calculate the rate of reaction during the first minute, using **Fig. 11.2**.

Give your answer in cm^3/s .

Rate of reaction = cm^3/s [3]

- (ii) Explain why the mass of the flask and its contents decreases during the reaction.

.....

..... [1]

GRADEUP.UK

(d) Mia repeats the experiment at a **higher** temperature.

Which statements explain why the reaction is faster at a higher temperature?

Tick (✓) **two** boxes.

The particles move faster.

There are more frequent collisions.

The yield is higher at a higher temperature.

The particles are closer together.

The zinc breaks down into smaller pieces.

[2]

GRADEUP.UK

12 The table shows some properties of metals, polymers and clay ceramics:

Type of material	Effect of force on material	Electrical conductivity	Hardness
Metals	malleable	good	hard
Polymers	flexible	poor	soft
Clay ceramics	snaps

(a) Complete the table by adding the two missing properties of clay ceramics. [2]

(b) Layla has three different water jugs.
The jugs are made from aluminium, poly(ethene) and pottery (clay ceramic).

Draw lines to connect each **material** with its correct **property**.

Material	Property of jug
Aluminium	Softens easily when heated.
Poly(ethene)	Goes out of shape if dropped.
Pottery	Breaks if dropped.
	Rusts quickly.

[3]

(c) Poly(ethene) is made from ethene.

Complete the equation by drawing the structure of the repeating unit of poly(ethene).

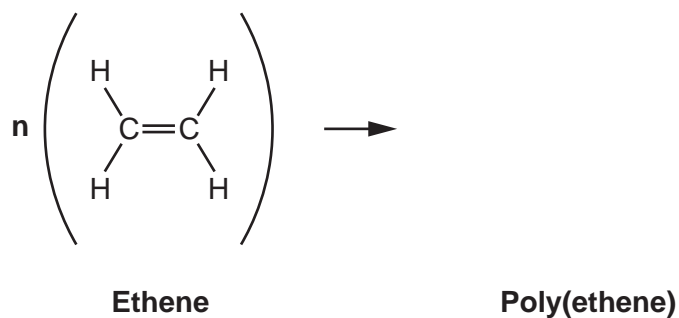

[1]

(d) Genes are made from the natural polymer DNA.

Which monomers make DNA?

Tick (✓) **one** box.

Cellulose

Nucleotides

Sugars

Unsaturated hydrocarbons

[1]

END OF QUESTION PAPER

ADDITIONAL ANSWER SPACE

If additional space is required, you should use the following lined page(s). The question number(s) must be clearly shown in the margin(s).

A large area of the page is filled with horizontal dotted lines for writing. A solid vertical line is positioned on the left side, creating a margin. A large, light grey watermark reading "GRADEUP.UK" is oriented diagonally across the center of the page.

A blank sheet of lined paper with a vertical margin line on the left and horizontal ruling lines. A large watermark 'GRADEUP.UK' is diagonally across the page.

