

Please check the examination details below before entering your candidate information

Candidate surname

Other names

Pearson Edexcel
Level 1/Level 2 GCSE (9–1)

Centre Number

| | | | | |
|--|--|--|--|--|
| | | | | |
|--|--|--|--|--|

Candidate Number

| | | | |
|--|--|--|--|
| | | | |
|--|--|--|--|

Time 1 hour 45 minutes

**Paper
reference**

1CH0/1F

Chemistry
PAPER 1:
Foundation Tier

You must have:
Calculator, ruler

Total Marks

Instructions

- Use **black** ink or ball-point pen.
- **Fill in the boxes** at the top of this page with your name, centre number and candidate number.
- Answer **all** questions.
- Answer the questions in the spaces provided – *there may be more space than you need.*
- Calculators may be used.
- Any diagrams may NOT be accurately drawn, unless otherwise indicated.
- You must **show all your working out** with **your answer clearly identified** at the **end of your solution**.

Information

- The total mark for this paper is 100.
- The marks for **each** question are shown in brackets – *use this as a guide as to how much time to spend on each question.*
- In questions marked with an **asterisk** (*), marks will be awarded for your ability to structure your answer logically showing how the points that you make are related or follow on from each other where appropriate.
- There is a periodic table on the back cover of the paper.

Advice

- Read each question carefully before you start to answer it.
- Try to answer every question.
- Check your answers if you have time at the end.
- Good luck with your examination.

Turn over ►

P67067A

©2021 Pearson Education Ltd.

1/1/1/



Pearson

DO NOT WRITE IN THIS AREA

DO NOT WRITE IN THIS AREA

DO NOT WRITE IN THIS AREA

GRADEUP.UK

BLANK PAGE



Answer ALL questions. Write your answers in the spaces provided.

Some questions must be answered with a cross .
If you change your mind about an answer, put a line through the box and then mark your new answer with a cross .

1 (a) Fertilisers are sometimes added to soil.

(i) State why fertilisers are added to soil.

(1)

(ii) Fertilisers contain compounds of different elements.
Three of these elements have the symbols K, N and P.

Use the periodic table to state the names of these three elements.

(2)

K

N

P

GRADEUP.UK

DO NOT WRITE IN THIS AREA

DO NOT WRITE IN THIS AREA

DO NOT WRITE IN THIS AREA



- (b) The fertiliser ammonium sulfate may be made by titrating ammonia solution with dilute sulfuric acid.

Three pieces of apparatus, **P**, **Q** and **R**, used to measure volumes of liquid are shown in Figure 1.

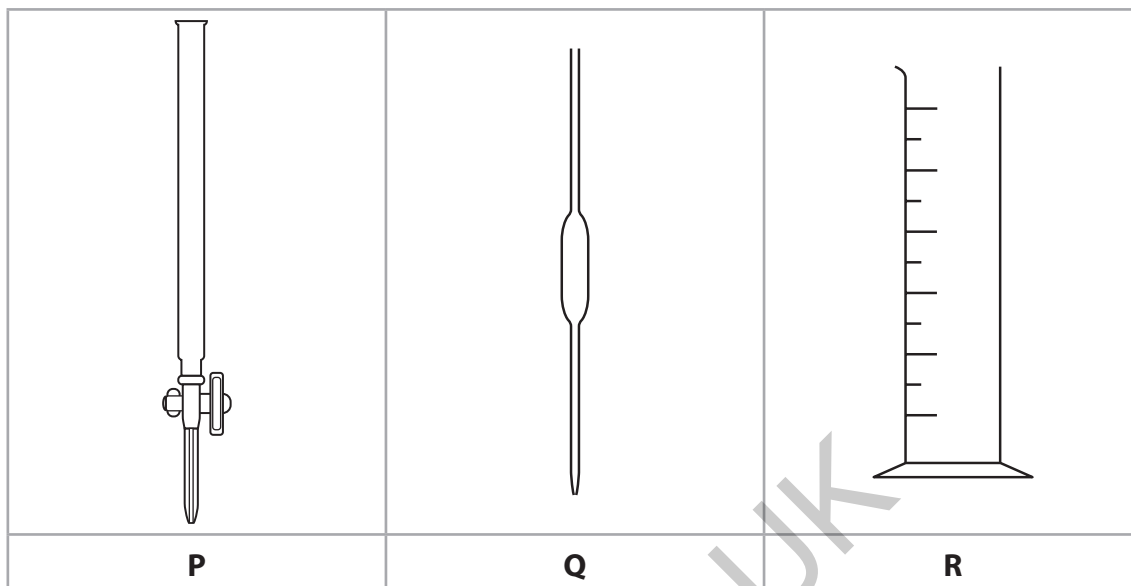

Figure 1

- (i) Give the names of the pieces of apparatus **P** and **Q**.

(2)

P

Q

- (ii) In the titration experiment, small volumes of dilute sulfuric acid are added gradually to the ammonia solution in a flask.

Give the letter, **P**, **Q** or **R**, of the piece of apparatus in Figure 1 that should be used to add the dilute sulfuric acid.

(1)

.....



(iii) The titration experiment is used to produce a solution of ammonium sulfate.

Describe how solid ammonium sulfate should be obtained from this solution.

(2)

.....

.....

.....

.....

(Total for Question 1 = 8 marks)

GRADEUP.UK

DO NOT WRITE IN THIS AREA

DO NOT WRITE IN THIS AREA

DO NOT WRITE IN THIS AREA



2 If liquid water is cooled below 0°C it turns into the solid, ice.

(a) (i) Give the name for the change of state from liquid to solid.

(1)

(ii) Here are five statements about ice and water.

Place ticks in boxes by the **two** statements that are correct.

(2)

| | |
|---|--------------------------|
| the molecules move faster in water than in ice | <input type="checkbox"/> |
| the molecules are more randomly arranged in ice than in water | <input type="checkbox"/> |
| the molecules start moving when water becomes ice | <input type="checkbox"/> |
| the molecules are arranged regularly in ice but not in water | <input type="checkbox"/> |
| the molecules have more energy in ice than in water | <input type="checkbox"/> |

GRADEUP.UK



(b) Figure 2 shows a label from a bottle of drinking water.

| Pure drinking water | |
|---|-----|
| Mass of dissolved solids in mg per 1000 cm ³ | |
| calcium ions | 60 |
| sodium ions | 2 |
| hydrogencarbonate ions | 200 |
| pH of water | |
| pH | 7 |

Figure 2

(i) Explain why this drinking water should not be described as pure water. (2)

(ii) State the information from Figure 2 that shows that the drinking water is neutral. (1)

(iii) Calculate the mass of calcium ions in 250 cm³ of this drinking water. (2)

mass = mg

(c) State how you know that calcium is a metal from its position in the periodic table. (1)

(Total for Question 2 = 9 marks)



3 (a) Hydrogen and oxygen are reactants in some fuel cells.

Which word equation shows the overall reaction that occurs in these fuel cells?

(1)

- A** hydrogen + oxygen → hydroxide
- B** hydrogen + oxygen → sulfuric acid
- C** hydrogen + oxygen → water
- D** hydrogen + oxygen → hydrochloric acid

(b) A torch contains a chemical cell.

The torch is turned on and then left on for many hours.

Describe what you would see happen when the torch is turned on and then left for many hours.

(2)

(c) A chemical cell can be made by placing two metals into an electrolyte.

Figure 3 shows how the voltage of a simple chemical cell can be measured.

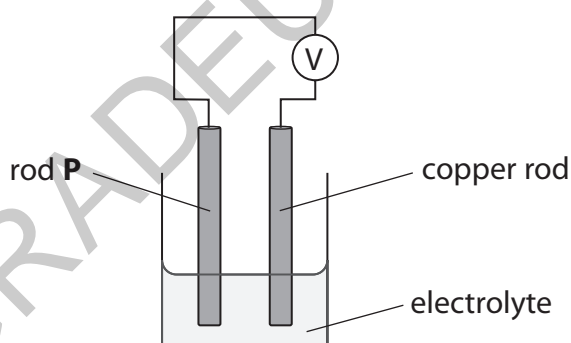

Figure 3



A student investigated how the voltage of this cell was affected by the metal used for the rods.

Which is the only variable that should be changed in the investigation? (1)

- A the size of the beaker
- B the element used for rod P
- C the concentration of the electrolyte
- D the temperature of the electrolyte

(d) (i) Explain why covering iron tools with a thin layer of grease prevents rusting. (2)

.....

.....

.....

(ii) Sacrificial protection is another way of preventing rusting.

An example of sacrificial protection is when lumps of zinc are connected to the iron-containing structure of an oil rig.

Explain how the zinc protects the iron from rusting. (2)

.....

.....

.....

(Total for Question 3 = 8 marks)

DO NOT WRITE IN THIS AREA

DO NOT WRITE IN THIS AREA

DO NOT WRITE IN THIS AREA



4 (a) When chromium reacts with oxygen, chromium oxide is formed.

(i) Write the word equation for this reaction.

(1)

..... + →

(ii) What type of reaction occurs when chromium reacts with oxygen?

(1)

- A condensation
- B evaporation
- C neutralisation
- D oxidation

(iii) Calculate the relative formula mass of chromium oxide, Cr_2O_3 .

(relative atomic masses: O = 16, Cr = 52)

(2)

.....

.....

relative formula mass =

(b) Three different metals are added to separate test tubes of acid.

The observations are shown in Figure 4.

| metal | observation |
|-----------|--------------------|
| silver | no change is seen |
| iron | very slow bubbling |
| magnesium | steady bubbling |

Figure 4

(i) Place the metals in order of reactivity from most to least reactive.

(1)

most reactive

.....

least reactive



(ii) Hydrogen is given off when magnesium reacts with acid.
The hydrogen is tested by collecting the gas in a test tube and igniting it.

What is the safest way to ignite the gas?

(1)

- A add fuel to the test tube
- B heat the test tube with a Bunsen burner
- C put a lighted splint at the open end of the test tube
- D put the test tube in an oven

(iii) State the observation made in this test that shows that the gas is hydrogen.

(1)

.....

.....

(c) Iron is extracted by heating iron oxide with carbon.
Electrolysis of molten iron oxide is not used to extract iron.

(i) State why iron can be extracted by heating iron oxide with carbon.

(1)

.....

.....

(ii) State why electrolysis is **not** used to extract iron.

(1)

.....

.....

.....

.....

(Total for Question 4 = 9 marks)

DO NOT WRITE IN THIS AREA

DO NOT WRITE IN THIS AREA

DO NOT WRITE IN THIS AREA

GRADEUP.UK



5 Ammonia is made by reacting nitrogen with hydrogen.

(a) The nitrogen and hydrogen are obtained from raw materials.

Draw one straight line from each gas to the raw material it is obtained from.

(2)

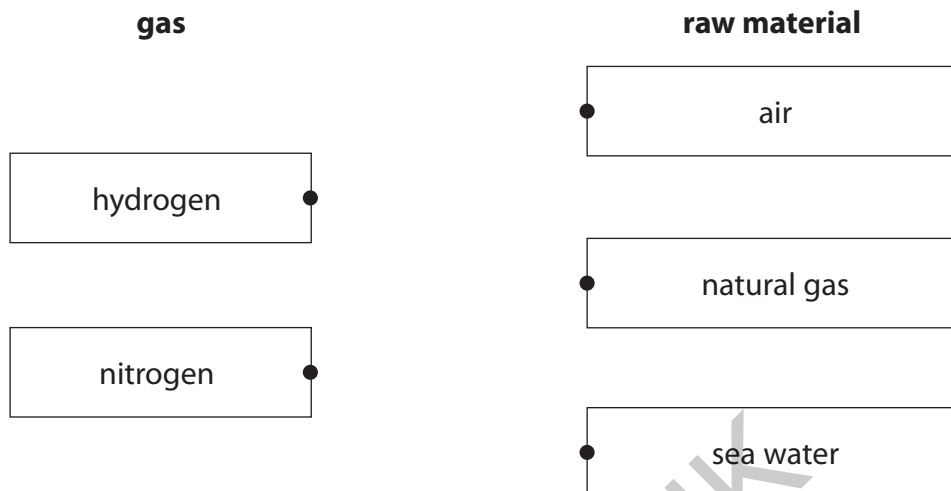

(b) When nitrogen and hydrogen are reacted together, the reaction can reach a dynamic equilibrium.

Use words from the box to complete the sentences about dynamic equilibrium.

(2)

backward different equal faster reversible

In a dynamic equilibrium two reactions occur at the same time.

These are the forward reaction and the reaction.

The rates of the two reactions are

(c) The reaction between nitrogen and hydrogen happens at a pressure of 200 atmospheres.

Another unit of pressure is Pascals, Pa (1 atmosphere = 101 325 Pa).

Calculate the value of 200 atmospheres in Pascals.

(2)

pressure = Pa



(d) Figure 5 shows molecules of nitrogen, hydrogen and ammonia before the reaction and at equilibrium.

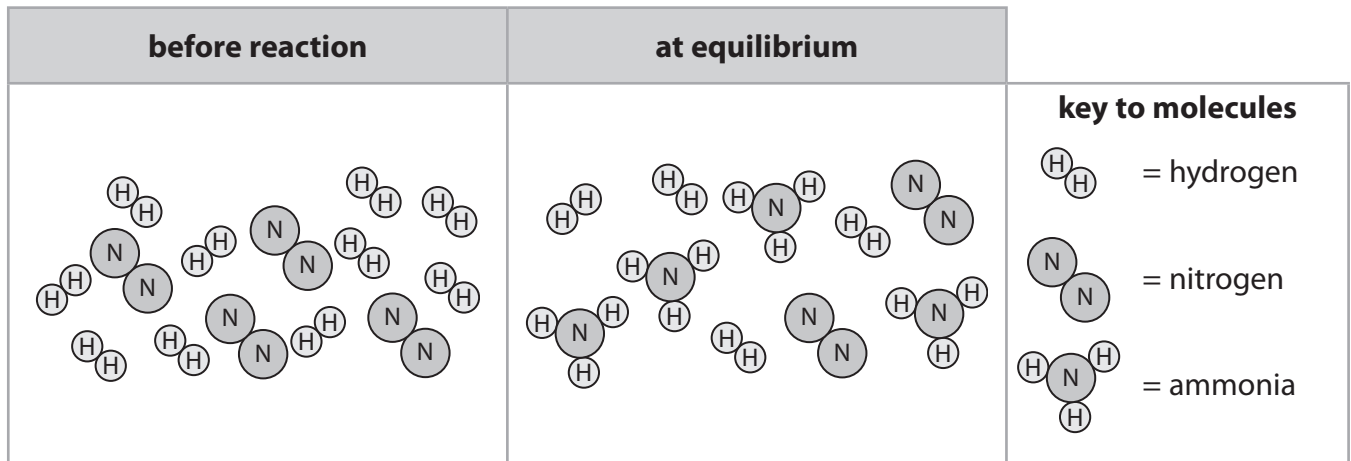

Figure 5

(i) Complete the table showing

- the number of hydrogen molecules before reaction
- the number of hydrogen molecules at equilibrium
- the change in the number of hydrogen molecules.

(1)

| | number of molecules before reaction | number of molecules at equilibrium | change in number of molecules |
|----------|-------------------------------------|------------------------------------|-------------------------------|
| nitrogen | 4 | 2 | -2 |
| hydrogen | | | |
| ammonia | 0 | 4 | +4 |

(ii) Complete the equation for this reaction.

(2)

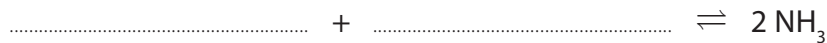

(Total for Question 5 = 9 marks)



- 6 (a) Hydrochloric acid reacts with solid **B**.
Solid **B** is an alkali.

A student carries out an experiment to see how the pH changes when different masses of solid **B** are added to dilute hydrochloric acid.

The student uses the following method.

step 1 use a measuring cylinder to measure out 100cm^3 of dilute hydrochloric acid

step 2 pour the acid into a beaker

step 3 measure the pH with a pH probe

step 4 add half a spatula of solid **B** and stir

step 5 repeat steps 3 and 4 until the pH stops changing.

- (i) Give a safety precaution that should be taken during the experiment. (1)

- (ii) Give an improvement to step 4 that would produce more accurate results. (1)

- (iii) What is the most likely change in pH during the experiment? (1)

- A** from 1 to 7
 B from 1 to 12
 C from 7 to 12
 D from 12 to 1

- (iv) If some methyl orange indicator is added to the acid in step 2, the mixture changes colour during the experiment.

State the colour change. (2)

colour at start in acid colour at end



- (b) Concentrated hydrochloric acid can be broken down using electricity. The apparatus that can be used is shown in Figure 6.

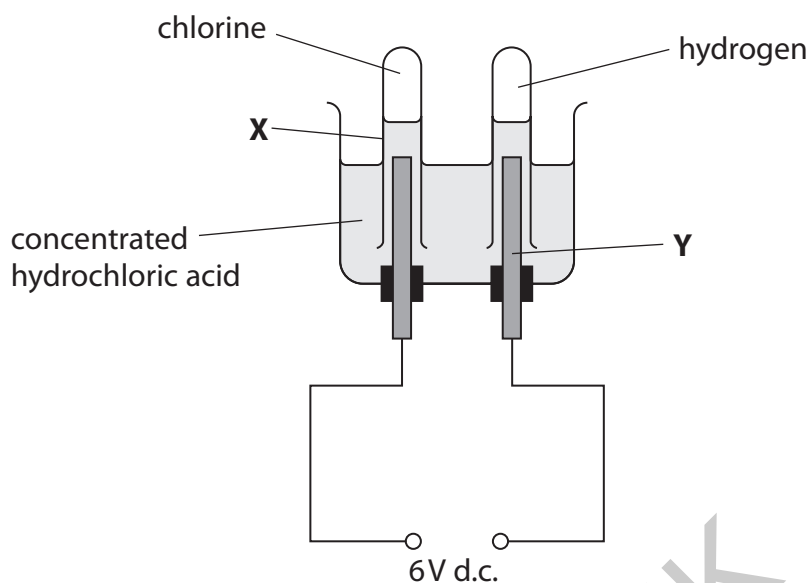

Figure 6

- (i) Give the name of the piece of apparatus labelled X. (1)

- (ii) The rod labelled Y in Figure 6 is made of graphite.
What is the name of this piece of apparatus? (1)

- A electrode
- B electrolysis
- C electrolyte
- D electron

- (iii) Give **one** reason why graphite is a suitable material to make Y. (1)

- (iv) Complete the balanced equation for the reaction that occurs. (1)

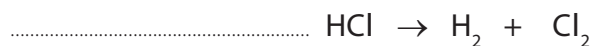

(Total for Question 6 = 9 marks)

DO NOT WRITE IN THIS AREA

DO NOT WRITE IN THIS AREA

DO NOT WRITE IN THIS AREA



7 (a) This question is about the metal gold.

(i) Gold can be hammered into shape.

State the name of this property.

(1)

(ii) Gold alloys can be used to repair teeth.

One reason that gold alloys are used is that they can be hammered into shape.

Give **one other** reason why gold alloys are used to repair teeth.

(1)

(b) A gold alloy contains 78% gold by mass.

Calculate the mass of gold in 2.00 kg of this alloy.

Give your answer in grams.

(3)

mass = g

GRADEUP.UK



- (c) A substance used to purify gold is kept in a container.
There are some hazard symbols on the container.

Draw one straight line from each hazard symbol to its meaning.

(2)

hazard symbol

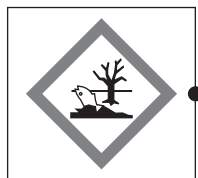

meaning

corrosive

flammable

hazardous to the
environment

oxidising

GRADEUP.UK



*(d) Some gold alloys contain copper.

Copper reacts with oxygen when heated.

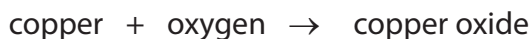

A teacher calculates that 1.20g of copper reacts completely with oxygen to form 1.50g of copper oxide.

A student heats 1.20g of copper pieces in a container.
Then they heat 1.20g of copper powder in another container.
After heating, the mass of the solid in the containers is found.

The results are shown in Figure 7.

| | colour before heating | mass before heating in g | time of heating in mins | colour after heating | mass after heating in g |
|---------------|-----------------------|--------------------------|-------------------------|----------------------|-------------------------|
| copper pieces | red-brown | 1.20 | 5 | black | 1.28 |
| copper powder | red-brown | 1.20 | 10 | black | 1.42 |

Figure 7

Explain the observations and give reasons why the masses after heating are less than expected.

(6)

.....

.....

.....

.....

.....

.....

.....

.....

.....

.....

.....

.....

.....

.....

.....

.....

.....

.....

.....

.....

.....

.....

.....



DO NOT WRITE IN THIS AREA

DO NOT WRITE IN THIS AREA

DO NOT WRITE IN THIS AREA

GRADEUP.UK

(Total for Question 7 = 13 marks)



P 6 7 0 6 7 A 0 1 9 2 8

8 The scientist John Dalton lived over 200 years ago.

(a) John Dalton suggested an early model of atoms.

When Dalton first described atoms he said that

- all elements are made of atoms
- atoms are not formed of any smaller particles
- all atoms of the same element are identical.

Give two differences between Dalton's model of atoms and today's model of atoms.

(2)

1

2

(b) Dalton also investigated different gases.

One of the gases that Dalton investigated was ethene.

The structure of one molecule of ethene is shown in Figure 8.

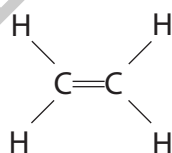

Figure 8

Give the molecular formula and the empirical formula of ethene.

(2)

molecular formula

empirical formula



(c) Another gas that Dalton investigated was chlorine.

Chlorine gas reacts with water.

The two products are a solution of hydrogen chloride and the substance HClO.

(i) Complete the balanced equation for this reaction, including the three missing state symbols.

(3)

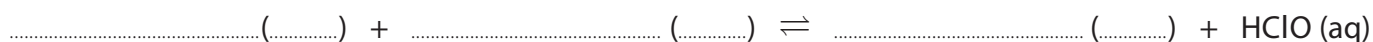

(ii) Hydrogen chloride solution is acidic.

The formulae of four ions are shown in Figure 9.

| | | | |
|----------------|----------------|-----------------|-----------------|
| H ⁺ | H ⁻ | Cl ⁺ | Cl ⁻ |
|----------------|----------------|-----------------|-----------------|

Figure 9

Give the formula of the ion in Figure 9 that causes the hydrogen chloride solution to be acidic.

(1)

formula

(iii) An acid reacts with an alkali.

Give the name of this type of reaction.

(1)

(iv) Describe what you would **see** when some copper carbonate powder is added to a beaker of dilute sulfuric acid.

(2)

(Total for Question 8 = 11 marks)



9 (a) A sample of potable water contains impurities.

Why is this sample of water potable even though it contains impurities?

(1)

- A** the impurities have no smell
- B** the impurities are colourless
- C** the impurities are harmless
- D** the impurities are soluble

(b) Waste water can be used to produce drinking water.

The processes used include sedimentation, filtration and chlorination.

(i) What is sedimentation?

(1)

- A** the waste water is heated so the impurities evaporate
- B** the waste water has an acid added to remove impurities
- C** the impurities in the waste water settle to the bottom of their container
- D** the impurities in the waste water are bleached

(ii) State why the waste water is filtered.

(1)

(iii) State the reason for chlorination.

(1)



- (c) Some salts can be added to waste water to remove impurities. In an experiment, different masses of salt **A** were added to 1000 cm^3 samples of waste water. The experiment was repeated with salt **B**. The percentages of impurities removed from the waste water are shown in Figure 10.

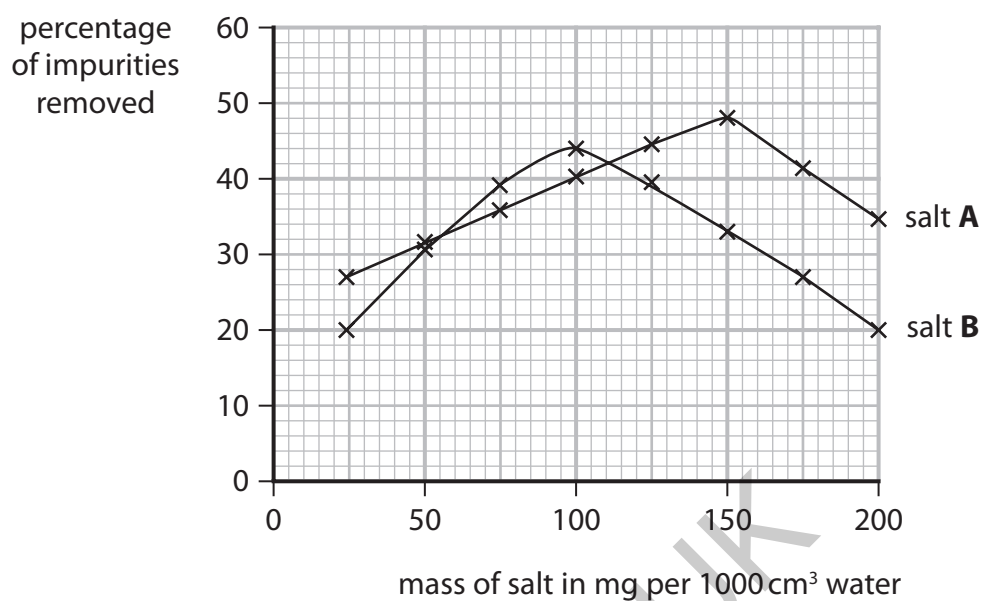

Figure 10

It was concluded that the best way to purify 1000 cm^3 of the waste water is to add 100 mg of salt **B**.

Use the information about salt **A** and salt **B** in Figure 10 to evaluate this conclusion.

(3)



*(d) A sample of water was contaminated with a dissolved solid.

Devise a plan to separate pure water from this mixture, including a test to show that the water obtained is neutral.

You may use some or all of the apparatus shown in Figure 11 and any other laboratory apparatus.

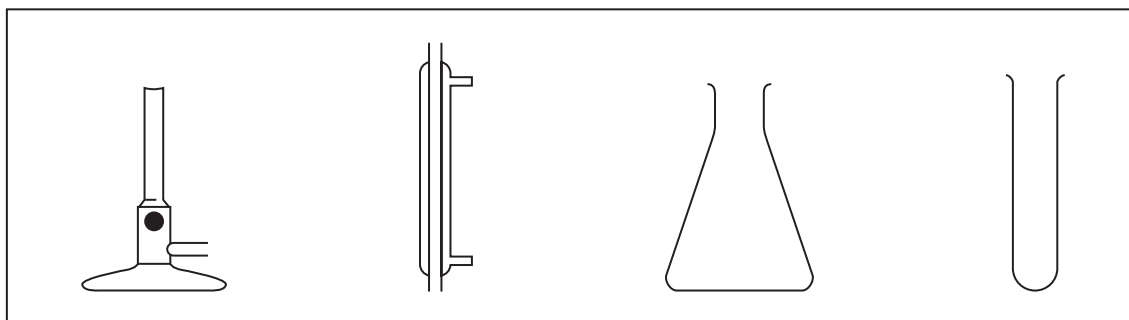

Figure 11

(6)

GRADEUP.UK



DO NOT WRITE IN THIS AREA

DO NOT WRITE IN THIS AREA

DO NOT WRITE IN THIS AREA

GRADEUP.UK

(Total for Question 9 = 13 marks)



P 6 7 0 6 7 A 0 2 5 2 8

10 Aluminium alloys are used instead of pure aluminium in aircraft manufacture.

- (a) Explain, in terms of the arrangement of metal particles, why aluminium alloys are stronger than pure aluminium.

(3)

- (b) A 695.0 g sample of an aluminium-magnesium alloy contains 2.00% by mass of magnesium.

Calculate the mass of aluminium in this sample.

(2)

mass of aluminium = g

- (c) Figure 12 shows a graph of the relative strength of aluminium-magnesium alloys when the percentage by mass of magnesium in the alloy is changed.

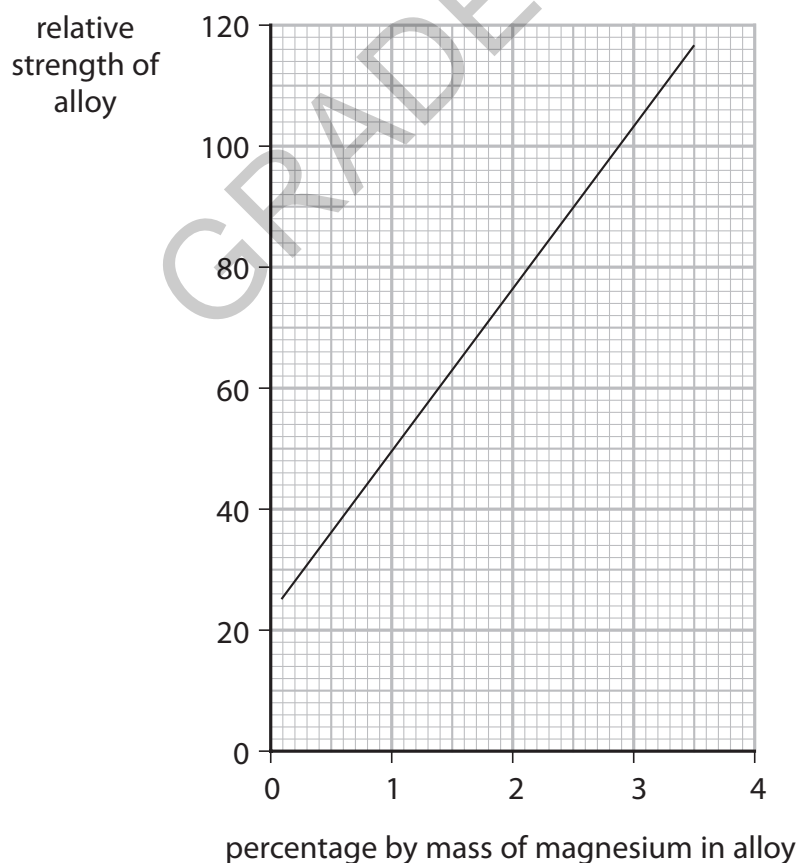

Figure 12



(i) Describe what Figure 12 shows about the relative strength of these alloys when the percentage by mass of magnesium changes.

(2)

(ii) Determine, using Figure 12, the percentage by mass of aluminium in an aluminium-magnesium alloy with a relative strength of 103.

(2)

percentage by mass of aluminium =

(d) Metal objects can be electroplated with gold.

Give two reasons why metal objects are electroplated with gold.

(2)

1

2

(Total for Question 10 = 11 marks)

TOTAL FOR PAPER = 100 MARKS



The periodic table of the elements

| | 1 | 2 | 3 | 4 | 5 | 6 | 7 | 0 | | | | | | | | | | |
|--|-----------------------------------|------------------------------------|-------------------------------------|------------------------------------|------------------------------------|-------------------------------------|---------------------------------------|------------------------------------|----------------------------------|------------------------------------|---------------------------------|----------------------------------|-----------------------------------|------------------------------------|-----------------------------------|------------------------------------|-----------------------------------|----------------------------------|
| | 7 Li lithium 3 | 9 Be beryllium 4 | 11 Na sodium 11 | 12 Mg magnesium 12 | 13 Al aluminium 13 | 14 C carbon 6 | 15 N nitrogen 7 | 16 O oxygen 8 | 17 F fluorine 9 | 18 Ne neon 10 | | | | | | | | |
| | 19 K potassium 19 | 20 Ca calcium 20 | 21 Sc scandium 21 | 22 Ti titanium 22 | 23 V vanadium 23 | 24 Cr chromium 24 | 25 Mn manganese 25 | 26 Fe iron 26 | 27 Co cobalt 27 | 28 Ni nickel 28 | 29 Cu copper 29 | 30 Zn zinc 30 | 31 Ga gallium 31 | 32 Ge germanium 32 | 33 As arsenic 33 | 34 Se selenium 34 | 35 Br bromine 35 | 36 Kr krypton 36 |
| | 37 Rb rubidium 37 | 38 Sr strontium 38 | 39 Y yttrium 39 | 40 Zr zirconium 40 | 41 Nb niobium 41 | 42 Mo molybdenum 42 | 43 Tc technetium [98] | 44 Ru ruthenium 44 | 45 Rh rhodium 45 | 46 Pd palladium 46 | 47 Ag silver 47 | 48 Cd cadmium 48 | 49 In indium 49 | 50 Sn tin 50 | 51 Sb antimony 51 | 52 Te tellurium 52 | 53 I iodine 53 | 54 Xe xenon 54 |
| | 55 Cs caesium 55 | 56 Ba barium 56 | 57 La* lanthanum 57 | 72 Hf hafnium 72 | 73 Ta tantalum 73 | 74 W tungsten 74 | 75 Re rhenium 75 | 76 Os osmium 76 | 77 Ir iridium 77 | 78 Pt platinum 78 | 79 Au gold 79 | 80 Hg mercury 80 | 81 Tl thallium 81 | 82 Pb lead 82 | 83 Bi bismuth 83 | 84 Po polonium 84 | 85 At astatine 85 | 86 Rn radon 86 |

| | | |
|---|----------|---|
| 1 | H | 1 |
| | hydrogen | |

Key

relative atomic mass
atomic symbol
name
atomic (proton) number

* The elements with atomic numbers from 58 to 71 are omitted from this part of the periodic table.
The relative atomic masses of copper and chlorine have not been rounded to the nearest whole number.

