

Please check the examination details below before entering your candidate information

Candidate surname

Other names

Centre Number

Candidate Number

Pearson Edexcel

Level 1/Level 2 GCSE (9–1)

Tuesday 19 May 2020

Morning (Time: 1 hour 30 minutes)

Paper Reference **1MA1/1F**

Mathematics

Paper 1 (Non-Calculator)

Foundation Tier

You must have: Ruler graduated in centimetres and millimetres, protractor, pair of compasses, pen, HB pencil, eraser. Tracing paper may be used.

Total Marks

Instructions

- Use **black** ink or ball-point pen.
- **Fill in the boxes** at the top of this page with your name, centre number and candidate number.
- Answer **all** questions.
- Answer the questions in the spaces provided – *there may be more space than you need.*
- You must **show all your working**.
- Diagrams are **NOT** accurately drawn, unless otherwise indicated.
- **Calculators may not be used.**



Information

- The total mark for this paper is 80
- The marks for **each** question are shown in brackets – *use this as a guide as to how much time to spend on each question.*

Advice

- Read each question carefully before you start to answer it.
- Keep an eye on the time.
- Try to answer every question.
- Check your answers if you have time at the end.

Turn over ►

P62274RA

©2020 Pearson Education Ltd.

1/1/1/1/1/1/



P 6 2 2 7 4 R A 0 1 2 0



Pearson

Answer ALL questions.

Write your answers in the spaces provided.

You must write down all the stages in your working.

- 1 Write the following numbers in order of size.
Start with the smallest number.

0.32 0.4 0.35 0.309

.....
(Total for Question 1 is 1 mark)

- 2 Here is a list of numbers.

5 11 18 22 29

From the list, write down a multiple of 3

.....
(Total for Question 2 is 1 mark)

- 3 Write 4.666 correct to the nearest whole number.

.....
(Total for Question 3 is 1 mark)

- 4 Write $\frac{3}{4}$ as a decimal.

.....
(Total for Question 4 is 1 mark)

- 5 Write down the value of the 7 in the number 8765

.....
(Total for Question 5 is 1 mark)

DO NOT WRITE IN THIS AREA

DO NOT WRITE IN THIS AREA

DO NOT WRITE IN THIS AREA



DO NOT WRITE IN THIS AREA

DO NOT WRITE IN THIS AREA

DO NOT WRITE IN THIS AREA

6 Gita spins a fair 8-sided spinner.

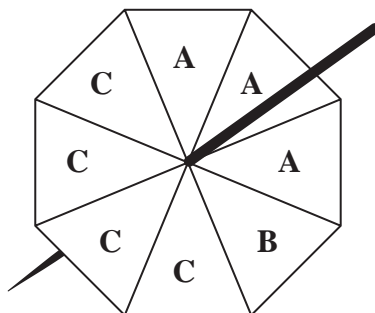

(a) On the probability scale, mark with a cross (×) the probability that the spinner will land on C.

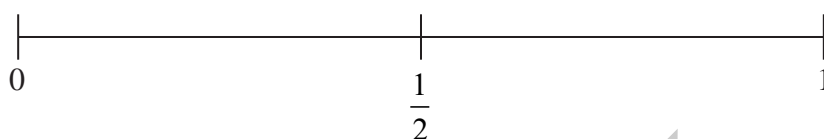

(1)

(b) On the probability scale, mark with a cross (×) the probability that the spinner will land on D.

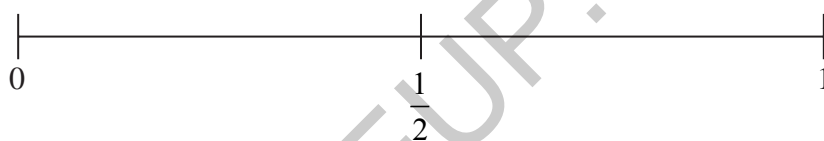

(1)

(Total for Question 6 is 2 marks)

GRADEUP.UK

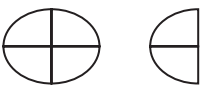

- 7 The incomplete pictogram shows information about the number of eggs sold from a farm shop on Monday.

Monday	
Tuesday	
Wednesday	

Key:

On Monday the shop sold 18 eggs.

On Tuesday the shop sold 24 eggs.

On Wednesday the shop sold 27 eggs.

Use this information to complete the pictogram and the key.

(Total for Question 7 is 4 marks)

GRADEUP.UK



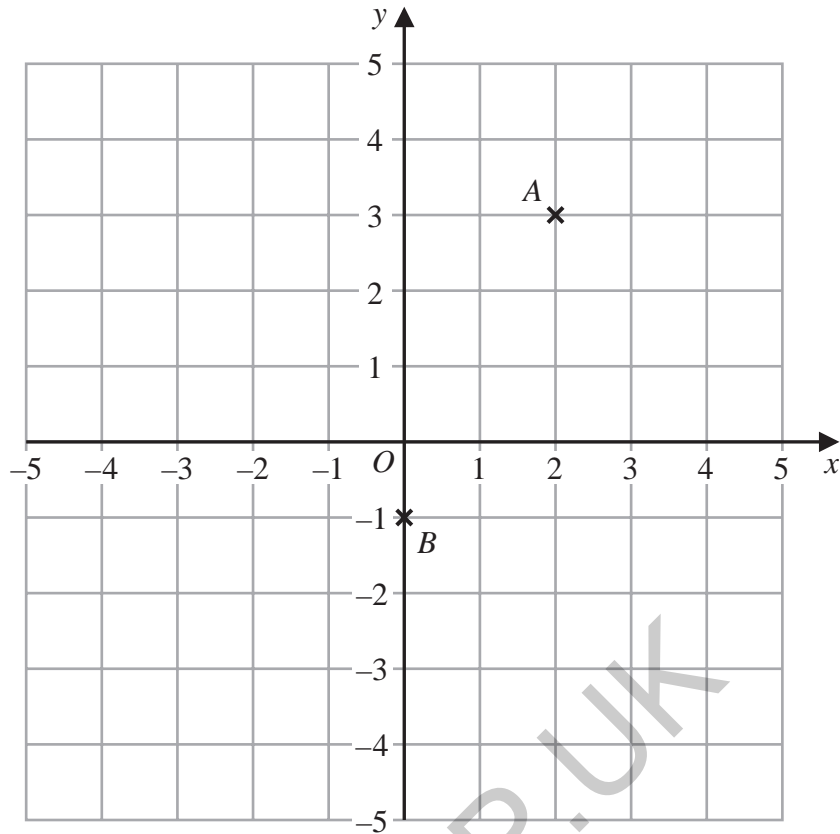

(a) Write down the coordinates of the point A.

(.....,)
(1)

(b) Write down the coordinates of the point B.

(.....,)
(1)

(c) On the grid, mark with a cross (X) the point $(-2, 1)$
Label this point C.

(1)

(Total for Question 8 is 3 marks)



- 9 (a) A bag contains red counters and blue counters only.

number of red counters : number of blue counters = 3 : 4

Write down the fraction of the counters that are red.

.....
(1)

- (b) Write the ratio 12 : 30 in the form 1 : n

.....
(2)

(Total for Question 9 is 3 marks)

- 10 Jenny has 12 marbles.

$\frac{1}{4}$ of these 12 marbles are large.

The rest of these 12 marbles are small.

Each large marble has a weight of 70 grams.

Each small marble has a weight of 50 grams.

Work out the total weight of the 12 marbles.

..... grams

(Total for Question 10 is 4 marks)



DO NOT WRITE IN THIS AREA

DO NOT WRITE IN THIS AREA

DO NOT WRITE IN THIS AREA

11

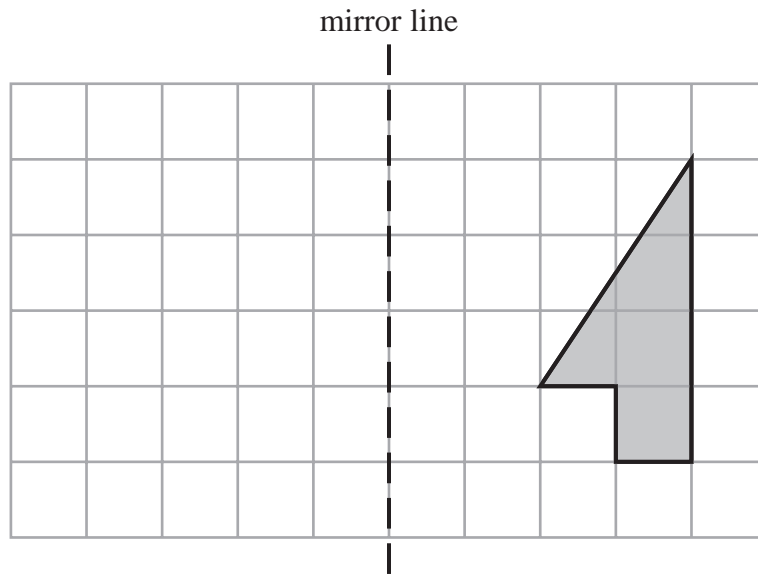

Reflect the shaded shape in the mirror line.

(Total for Question 11 is 2 marks)

12 The diagram shows a number machine.



(a) Find the output when the input is 7

.....
(1)

(b) Find the input when the output is 41

.....
(2)

(Total for Question 12 is 3 marks)



13 The diagram shows two points, *A* and *B*, on a map.

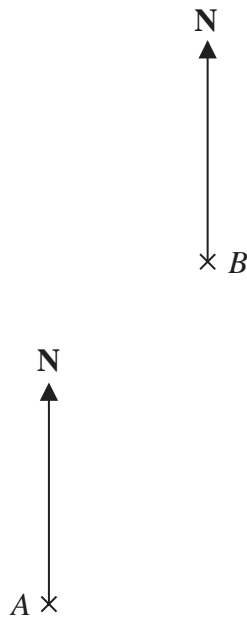

Diagram accurately drawn

Scale: 1 to 25 000

(a) Find the bearing of *B* from *A*.

.....
(1)

(b) Work out the real distance between *A* and *B*.
Give your answer in kilometres.

..... kilometres
(3)

(Total for Question 13 is 4 marks)



DO NOT WRITE IN THIS AREA

DO NOT WRITE IN THIS AREA

DO NOT WRITE IN THIS AREA

14 Ishmael asked 30 students at college to tell him the sport they each like the best from cricket or tennis or swimming.

- 11 of the 20 female students said swimming.
- 2 of the male students said tennis.
- 5 students said cricket.

The number of male students who said cricket was the same as the number of male students who said swimming.

Complete the two-way table.

	Cricket	Tennis	Swimming	Total
Male students				
Female students				20
Total				30

(Total for Question 14 is 3 marks)

15 Jamil makes a drink by mixing
1 part of orange squash with 9 parts of water.

He uses 750 millilitres of orange squash.

Jamil is going to put the drink he has mixed into 1 litre bottles.

Work out the greatest number of 1 litre bottles that Jamil can completely fill.

(Total for Question 15 is 3 marks)



16 The table gives information about the number of points scored by each of 16 students in a game.

Number of points	Frequency
0	1
1	3
2	5
3	4
4	3

Tina worked out the median of the number of points scored to be 5

(a) Explain why it is **not** possible for the median to be 5

.....

.....

.....

(1)

Tina also worked out the total number of points scored by the 16 students in the game. Here is her working.

$$(0 \times 1) + (1 \times 3) + (2 \times 5) + (3 \times 4) + (4 \times 3) = 1 + 3 + 10 + 12 + 12 = 38$$

Tina made a mistake in her working to find the total number of points scored.

(b) Describe the mistake that Tina made.

.....

.....

.....

(1)

(Total for Question 16 is 2 marks)



DO NOT WRITE IN THIS AREA

DO NOT WRITE IN THIS AREA

DO NOT WRITE IN THIS AREA

17 In a shop, a TV has a normal price of £500
The shop has a sale.

On Monday, the normal price of the TV is reduced by $\frac{1}{10}$ to give the sale price.

On Tuesday, the sale price of the TV is reduced by 20%

Chris wants to buy the TV.
He has £400 to spend on the TV.

Does Chris have enough money to buy the TV on Tuesday?
You must show how you get your answer.

GRADEUP.UK

(Total for Question 17 is 5 marks)



18 Work out an estimate for $\frac{790 \times 289}{49}$

.....
(Total for Question 18 is 3 marks)

19 (a) Expand $x(x - 4)$

.....
(1)

(b) Factorise $15y - 10$

.....
(1)

(c) Solve $7(f - 5) = 28$

$f =$
(2)

(Total for Question 19 is 4 marks)

DO NOT WRITE IN THIS AREA

DO NOT WRITE IN THIS AREA

DO NOT WRITE IN THIS AREA



DO NOT WRITE IN THIS AREA

DO NOT WRITE IN THIS AREA

DO NOT WRITE IN THIS AREA

20 The first five terms of an arithmetic sequence are

1 4 7 10 13

Write down an expression, in terms of n , for the n th term of this sequence.

.....

(Total for Question 20 is 2 marks)

21 Show that

$$2\frac{1}{3} \times 3\frac{3}{4} = 8\frac{3}{4}$$

GRADEUP.UK

(Total for Question 21 is 3 marks)



22 The diagram shows four graphs.

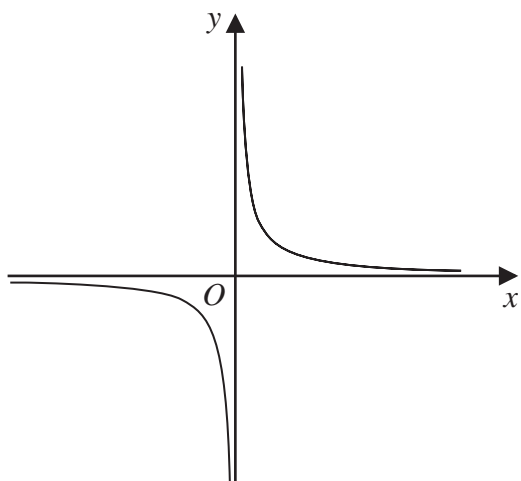

Graph A

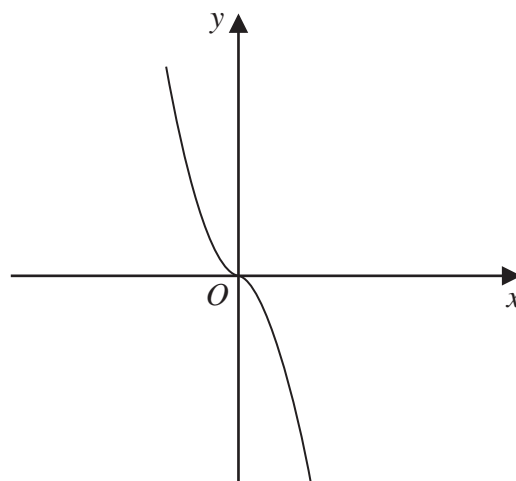

Graph B

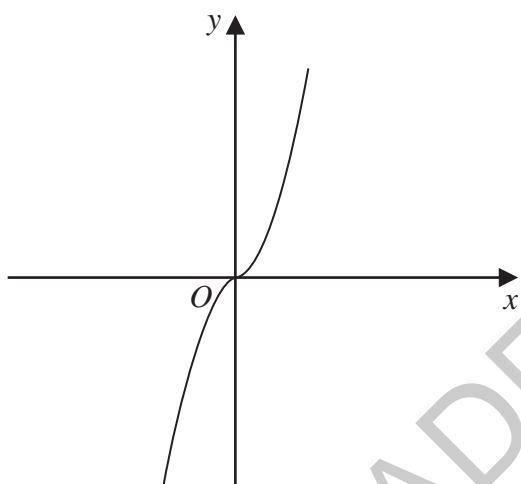

Graph C

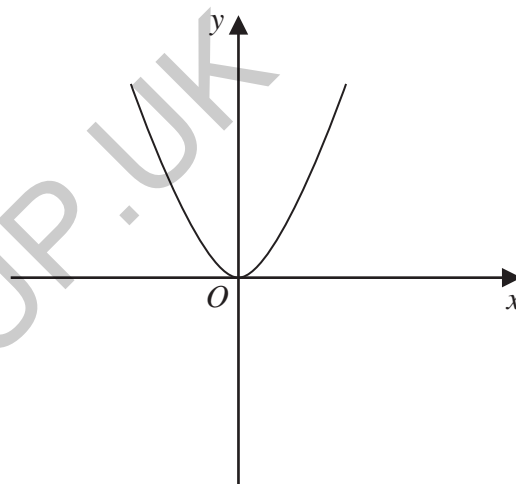

Graph D

Each of the equations in the table is the equation of one of the graphs.

Complete the table.

Equation	Letter of graph
$y = -x^3$	
$y = x^3$	
$y = x^2$	
$y = \frac{1}{x}$	

(Total for Question 22 is 2 marks)



DO NOT WRITE IN THIS AREA

DO NOT WRITE IN THIS AREA

DO NOT WRITE IN THIS AREA

23 The diagram shows four triangles.

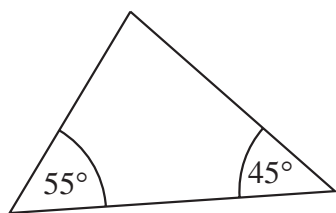

Triangle A

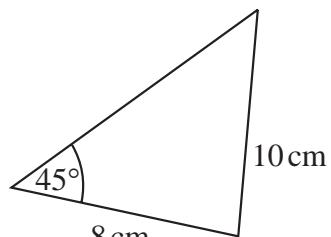

Triangle B

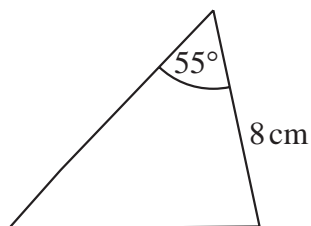

Triangle C

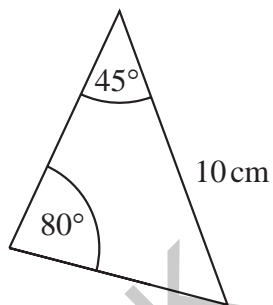

Triangle D

Two of these triangles are congruent.

Write down the letters of these two triangles.

..... and

(Total for Question 23 is 1 mark)

24 Sean pays £10 for 24 chocolate bars.

He sells all 24 chocolate bars for 50p each.

Work out Sean's percentage profit.

..... %

(Total for Question 24 is 3 marks)



25 ADC is a triangle.

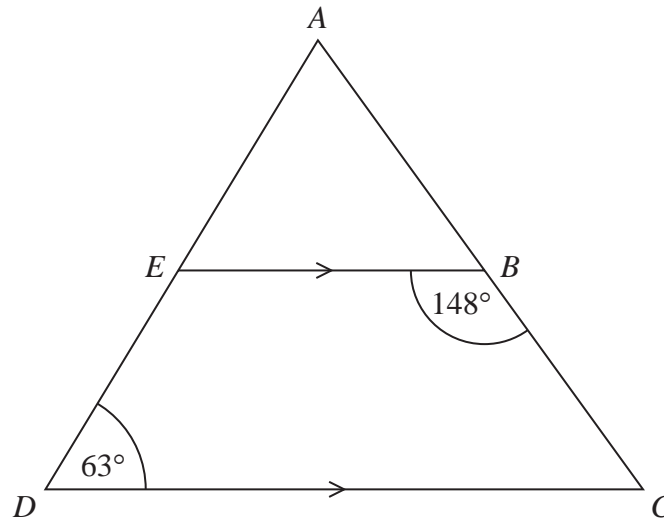

AED and ABC are straight lines.
 EB is parallel to DC .

Angle $EBC = 148^\circ$

Angle $ADC = 63^\circ$

Work out the size of angle EAB .

You must give a reason for each stage of your working.

DO NOT WRITE IN THIS AREA

DO NOT WRITE IN THIS AREA

DO NOT WRITE IN THIS AREA

(Total for Question 25 is 5 marks)



26 The table shows information about the heights, in cm, of a group of Year 9 girls.

least height	150 cm
median	165 cm
greatest height	170 cm

This stem and leaf diagram shows information about the heights, in cm, of a group of 15 Year 9 boys.

15	8 9 9
16	4 5 7 7 8
17	0 3 4 4 7
18	0 2

Key: 15 | 8 represents 158 cm

Compare the distribution of the heights of the girls with the distribution of the heights of the boys.

(Total for Question 26 is 3 marks)



27 The diagram shows a prism placed on a horizontal floor.

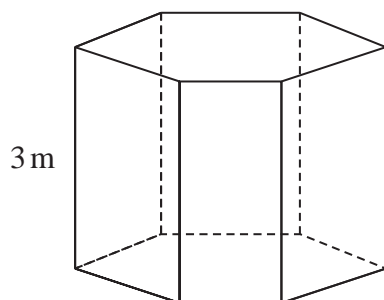

$$\text{pressure} = \frac{\text{force}}{\text{area}}$$

The prism has height 3 m

The volume of the prism is 18 m^3

The pressure on the floor due to the prism is 75 newtons/m^2

Work out the force exerted by the prism on the floor.

..... newtons

(Total for Question 27 is 3 marks)

28 Write these numbers in order of size.

Start with the smallest number.

6.72×10^5

67.2×10^{-4}

672×10^4

$0.000\,672$

.....

(Total for Question 28 is 2 marks)



29 Given that $\frac{a}{b} = \frac{2}{5}$ and $\frac{b}{c} = \frac{3}{4}$

find $a:b:c$

.....
(Total for Question 29 is 3 marks)

GRADEUP.UK



30 (a) Make q the subject of $p = 6q + 7$

.....
(2)

(b) Simplify $(m^{-2})^{-3}$

.....
(1)

(Total for Question 30 is 3 marks)

TOTAL FOR PAPER IS 80 MARKS

DO NOT WRITE IN THIS AREA

DO NOT WRITE IN THIS AREA

DO NOT WRITE IN THIS AREA

